

HARVIA SPARE PARTS

HARVIA

Sauna & Spa

Let's sauna.



Electric heaters



Wood burning heaters



Steam generators



Sauna control



Accessories



Sauna cabins



How to replace the heating elements



Heating elements compatibility



Harvia warranty terms and conditions, [harvia.com](https://www.harvia.com)

ELECTRIC HEATERS



Cilindro Corner
PCC70E 6.8kW / PCC90E 9.0kW
Itm.Nr. HPCCE704, HPCCE904



Cilindro Corner XE
PCC70XE 6.8kW / PCC90XE 9.0kW
Itm.Nr. HPCC704XE, HPCC904XE



Cilindro
PC70(E) 6.8 kW / PC90(E) 9.0 kW
Itm.Nr. HPCE700400M, HPC700400M, HPCE700400, HPCE700400H, HPC700400, HPC700400F, HPC700400H, HPC700400B, HPCE700400B, HPCE900400M, HPC900400M, HPCE900400, HPCE900400H, HPC900400, HPC900400F, HPC900400H, HPC900400B, HPCE900400B



Cilindro Plus
PP70(E/SP) 6.8 / PP90(E/SP) 9.0 kW
Itm.Nr. HPP700400SP, HPP900400SP, HPP700400, HPP900400, HPP700400E, HPP900400E



Cilindro Pro
PC100E/135E 13.2 kW / PC165E/200 19.8 kW
Itm.Nr. HPCE100400, HPCE165400, HPCE100400M, HPCE165400M



Cilindro (USA/CANADA)
PC60 6.0 kW / PC70 7.0 kW / PC80 8.0 kW / PC90 9.0 kW / 10.5 kW
Itm.Nr. HPCS6U1HB, HPCS8U1HB, HPCS9U1HB, HPCS7U3HB, HPC9U3HB, HPC7U1HB, HPC7U3HB, HPCS9U3HB



Cilindro (USA/CANADA)
PC60E 6.0 kW / PC70E 7.0 kW / PC80E 8.0 kW / PC90E 9.0 kW / PC110E 10.5 kW
Itm.Nr. HPCS6U1H, HPCS7U1H, HPCS8U1H, HPCS8U3H, HPCS9U1H, HPCS11U1H, HPCS11U3H



Cilindro XE/XW
PC70(XE/XW) 6.8 kW / PC90(XE/XW) 9.0 kW
Itm.Nr. HPC7004MXE, HPC704XE, HPC9004MXE, HPC904XE



Club Combi
K10,5GS 10.5 kW / K15GS 15 kW / K13,5GS 13.5 kW
Itm.Nr. HRKG110400S, HRKG135400S, HRKG150400S



Club
K11G 11kW / K13,5G 13.5kW / K15G 15 kW
Itm.Nr. HRKG110400, HRKG135400, HRKG150400, HRKG1002, HRKG1202, HRKG1502



Club (USA/CANADA)
K10G-U1 10 kW / K12.5G-U1 12.5 kW / K15G-U1 15 kW / K10G-U3 / K12.5G-U3 12.5 kW / K15G-U3 15 kW / K10G-U1W 10 kW / K12.5G-U1W 12.5 kW / K15G-U1W 15 kW / K10G-U3W 10 kW / K12.5G-U3W 12.5 kW / K15G-U3W 15 kW
Itm.Nr. HRKGU102083, HRKGU10240, HRKGU1020C1, HRKGU1024C, HRKGU122083, HRKGU122401, HRKGU1220C, HRKGU1224C, HRKGU152083, HRKGU152401, HRKGU1520C, HRKGU1524C, HRKGU102401



Delta

D23 2.3 kW / D36 3.6 kW

Itm.Nr. HD234M, HDE234M, HD294M, HDE294M, HD364M, HDE364M



Delta (JAPAN)

D36 2.7 kW

Itm.Nr. HD272M



Figaro

FG70(E) 6.8 kW / FG90(E) 9.0 kW

Itm.Nr. HFG700400M, HFG700400M, HFGE700400M, HFGE900400M, HFG700400V, HFG900400V, HFGE700400V, HFGE900400V



Forte

AFB40 4 kW / AFB60 6.0 kW / AFB90 9.0 kW

Itm.Nr. HAFB400400M, HAFB400400S, HAFB600400M, HAFB600400S, HAFB900400M, HAFB900400S



Glow Corner

TRC70 6.8 kW / TRC90 9.0 kW

Itm.Nr. HTRC700400, HTRC900400



Glow

TRT70XE 6.8 kW / TRT90XE 9.0 kW)

Itm.Nr. HTRT704XE, HTRT904XE



KIP (JAPAN)

KIP60E 5,5 kW 200 V / KIP80E 7,4 kW 200 V

Itm.Nr. HEK602S, HEK602M, HEK802S, HEK802M



KIP

KIP45(E) 4.5 kW / KIP60(E) 6.0 kW / KIP80(E) 8.0 kW / KIP90(E) 9.0 kW)

Itm.Nr. HBK450230, HBK600230, HBK800230, HBK450230S, HBK600230S, HBK800230S, HBK900230S, HEK900230, HEK900230S, HEK800230, HEK800230S, HEK450230, HEK450230S, HEK450230, HEK600230S, HEK600230



KIP (USA/CANADA)

KIP-30-B1 3.0 kW 240V / KIP-45-B1 4.5 kW 240V / KIP-60-B1 6.0 kW 240V / KIP-80-B1 8.0 kW 240V / KIP-30-B3 3.0 kW 208V / KIP-45-B3 4.5 kW 208V / KIP-60-B3 6.0 kW 208V / KIP-80-B3 8.0 kW 208V

Itm.Nr. KIP-30-B1, KIP-45-B1, KIP-60-B1, KIP-80-B1, KIP-30-B3, KIP-45-B3, KIP-60-B3, KIP-80-B3



Kivi

PI70 6.9 kW / PI90 9.0 kW

Itm.Nr. HPI700400, HPIE700400, HPI900400, HPIE900400



Legend (E/XW)

PO70(E/XW) 6.8 kW / PO110(E/XW) 10.8 kW

Itm.Nr. HPOE704, HPOE1104, HPO704XW, HPO1104XW



Legend (FC)

PO70FC 6.8 kW / PO110FC 10.8 kW

Itm.Nr. HPO704FC, HPO1104FC



Legend Pro

PO11E 11 kW / PO165E 16.5 kW

Itm.Nr. HPO110400M, HPO165400



Moderna XE

V45XE 4.5 kW / V60XE 6.0 kW / V80XE 8.0 kW
Itm.Nr. HVE454XEM, HVE604XEM, HVE804XEM



Modulo Alto

MDA165/200G 16.6 kW / 19.8 kW
Itm.Nr. HMDA1654G, HMDA1654GL, HMDA1654GR, HMDA1654C



Modulo

MD135(G/GR/GL/H) 13.6 kW / 160(G/GR/GL/H) 15.8 kW / 180(G/GR/GL/H) 18 kW
Itm.Nr. HMD135400, HMD1354H, HMD1354GL, HMD1354GR, HMD1354G, HMD160400, HMD1604H,
HMD1604GR, HMD1604GL, HMD1604G, HMD180400, HMD1804H, HMD1804GR, HMD1804GL, HMD1804G



Qube

9.0 / 10.5 kW
Itm.Nr. QUBE-090, QUBE-105



Qube

12.0 / 15.0 kW
Itm.Nr. QUBE-120, QUBE-150



Qube Combi

QU100S 10kW / QU135S 13.5 kW / QU160S 16 kW
Itm.Nr. HQU1004CM, HQU1354CM, HQU1604CM



Qube Pro

240 18-24 kW / Qube Pro 360 30-36 kW
Itm.Nr. QUBE-240, QUBE-360



Sähköri

KIP60 6.0 kW / KIP80 8.0 kW
HBH600400, HBH800400, HBH450400, HBH600400ST, HBH800400ST



Series 100-200

ST145(B/BE) 4.5 kW / ST160(B/BE) 6.0 kW / ST180(B/BE) 8.0 kW / ST190(B/BE) 9.0 kW / ST245BE 4.5
kW / ST260BE 6.0 kW / ST290BE 9.0 kW
Itm.Nr. ST145400B, ST145400BE, ST160400B, ST160400BE, ST180400B, ST180400BE, ST190400B,
ST190400BE, ST245400BE, ST260400BE, ST280400BE, ST290400BE



Series 100

ST136(B/BE) 3.6 kW
Itm.Nr. ST1364B, ST1364BE



Spirit (JAPAN)

SP60E 6,0 kW 200V / SP90E 9,0 kW 200 V
Itm.Nr. HSPE602M, HSPE902M



Spirit

SP60E 6.0 kW / SP90E 9.0 kW
Itm.Nr. HSPE604M, HSPE904M, HSP604MXW, HSP904MXW



Spirit (USA/CANADA)

SP60E 6.0 kW 240V 1ph / SP80E 8.0 kW 240V 1ph / SP90E 9.0 kW 240V 1ph
Itm.nr. HSPE60U1M, HSPE80U1M, HSPE90U1M



The Wall Combi

SW45S(A) 4.5 kW / SW70S(A) 7.0 kW / SW90S(A) 9.0 kW

Itm.Nr. HSW450400SA, HSW700400SA, HSW900400SA, HSW900400S, HSW450400S, HSW700400S



The Wall (JAPAN)

SW45(E) 4.5 kW 200V / SW60(E) 6.0 kW 200V / SW90(E) 9.0 kW 200V

Itm.Nr. HSW452M, HSW452M, HSW602M, HSW602M, HSW902M, HSW902M



The Wall

SW45(E) 4.5 kW / SW60(E) 6.0 kW / SW90(E) 9.0 kW

Itm.Nr. HSW450400, HSW450400M, HSW600400, HSW600400M, HSW900400, HSW900400M, HSW450400, HSW450400M, HSW600400, HSW600400M, HSW800400, HSW800400M



The Wall (USA/CANADA)

SW60 6.0 kW 240V / SW80 8.0 kW 208V

Itm.Nr. HSWS6U1B, HSWS8U1B, HSWS6U3B, HSWS8U3B, HSW6U1B, HSW8U1B, HSW6U3B, HSW8U3B



Vega

BC45(E) 4.5 kW / BC60(E) 6.0 kW / BC90(E) 9.0 kW

Itm.Nr. HCB450400S, HCB600400S, HCB800400S, HCB900400S, HCBE450400S, HCBE600400S, HCBE800400S, HCBE900400S



Vega Compact

BC23(E) 2.3 kW / BC35(E) 3.5 kW

Itm.Nr. HCB230400S, HCB350400S, HCBE230400S, HCBE350400S



Vega Compact (USA/CANADA)

1.7 kW / 1.9 kW / 3.5 kW

Itm.Nr. HCBU1912241, HCBU352401, HCBU1712241



Vega Pro

BC105 10.5 kW / BC135 13.5 kW / BC165 16.5 kW

Itm.Nr. HCB105400S, HCB135400S, HCB165400S



Virta Combi

HL70S(A) 7 kW / HL90S(A) 9 kW / HL110S(A) 11 kW

Itm.Nr. HL700400S, HL900400S, HL110400S, HL700400SA, HL900400SA, HL110400SA



Virta Combi (USA/CANADA)

Itm.Nr. HL11U1SA, HLS11U1SA, HL11U3SA, HLS11U3SA, HL6U1SA, HLS6U1SA, HL8U1SA, HLS8U1SA, HL9U1SA, HLS9U1SA, HL11U1S, HLS11U1S, HL11U3S, HLS11U3S, HL6U1S, HLS6U1S, HL8U1S, HLS8U1S, HL9U1S, HLS9U1S



Virta

HL70 6.8 kW / HL90 9.0 kW / HL110 10.8 kW

Itm.Nr. HL700400, HL900400, HL110400



Virta Pro Combi

HL135SA 13.5 kW / HL160SA 15.8 kW / HL220SA 21.6 kW

Itm.Nr. HL135400SA, HL160400SA, HL220400SA, HL220400SAX



Virta Pro

HL135 13.5 kW / HL160 15.8 kW / HL220 21.6 kW

Itm.Nr. HL135400, HL135400X, HL160400, HLS160400, HL160400X, HL220400, HLS220400, HL220400X



Virta Pro (USA/CANADA)
HL16U1 16 kW 240 V / HL20U3 20 kW 208V
Itm.Nr. HL16U1, HL20U3



Virta (USA/CANADA)
HL60E 6.0 kW / HL70E / HL80E 8.0 kW / HL90E 9.0 kW / HL110E 11 kW
Itm.Nr. HL6U1, HL7U1, HL8U1, HL9U1, HL11U1, HL11U3, HLS6U1, HLS7U1, HLS8U1, HLS9U1, HLS11U1, HLS11U3



Virta Wall Combi
HLW60S 6.0 kW / HLW90S 9.0 kW
Itm.Nr. HLW60SM, HLW90SM



Virta Wall
HLW45E 4.5 kW / HLW60E 6.0 kW / HLW75E 7.5 kW / HLW90E 9.0 kW
Itm.Nr. HLWE454M, HLWE604M, HLWE754M, HLWE904M



Cilindro Corner

PCC70E 6.8kW / PCC90E 9.0kW

Itm.Nr. HPCCE704, HPCCE904

No.	Name	Type	Item code	pcs
1	Heater element (2260 W)	PCC70E	SPZRH-720	3
2	Heater element (3000 W)	PCC90E	SPZSE-259	3
3	Temperature sensor (125°C limiter)		SP248	
4	Adjusting leg M10x60		SPZSA-442	

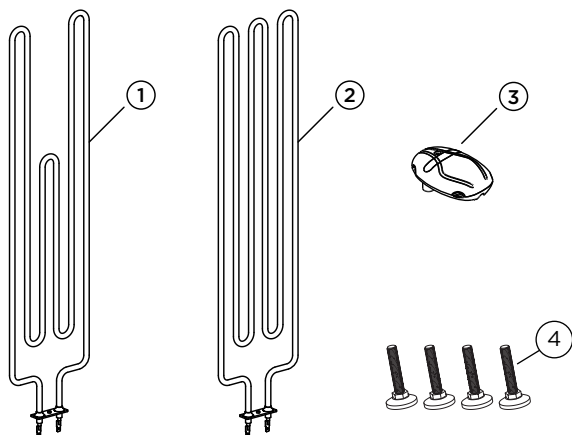

How to replace the heating elements?





Cilindro Corner XE

PCC70XE 6.8kW / PCC90XE 9.0kW

Itm.Nr. HPCC704XE, HPCC904XE

No.	Name	Type	Item code	pcs
1	Heater element (2260 W)	PCC70XE	SPZRH-720	3
2	Heater element (3000 W)	PCC90XE	SPZSE-259	3
3	Temperature sensor (125 °C)		SP248	
4	Circuit board		SP683	
5	Control panel		SP380	
6	Data cable, 5 m		SP311	
7	Power switch and cover, white		SPZSK-684	
8	Adjusting leg M10x60		SPZSA-442	

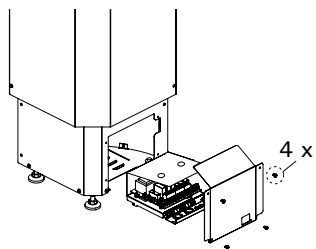
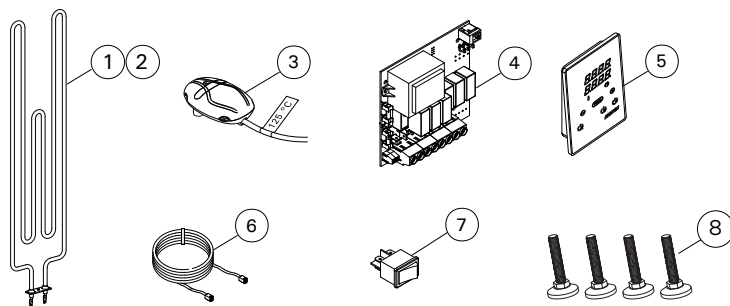



Cilindro

PC70(E) 6.8 kW / PC90(E) 9.0 kW

Itm.Nr. HPCE700400M, HPC700400M, HPCE700400, HPCE700400H, HPC700400, HPC700400F, HPC700400H, HPC700400B, HPCE700400B, HPCE900400M, HPC900400M, HPCE900400, HPCE900400H, HPC900400, HPC900400F, HPC900400H, HPC900400B, HPCE900400B

No.	Name	Type	Item code
1	Heater element 2260 W x 3	PC70/E/H/HE/F	SPZRH-720
	Heater element 3000 W x 3	PC90/E/H/HE/F	SPZSE-259
2	Temperature sensor 125 °C	PC-E/HE	SP248
3	Knob for thermostat	PC/-H/-F	SPZST-220
4	Thermostate/overheating limiter switch	PC/-H/-F	SPZSK-520
5	Timer	PC/-H/-F	SPZSK-510
6	Knob for timer	PC/-H/-F	SPZST-230
7	Contactors K1	PC90/H/F	SP225
8	Wall bracket PC		SP615
9	Support top plate		SPZSC-135
10	Support plate middle	PC/-H/-F	SPZSC-140
11	Adjustable leg (set of 4 pcs)		SPZSA-442

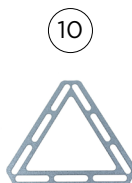
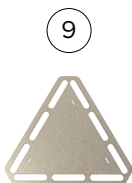
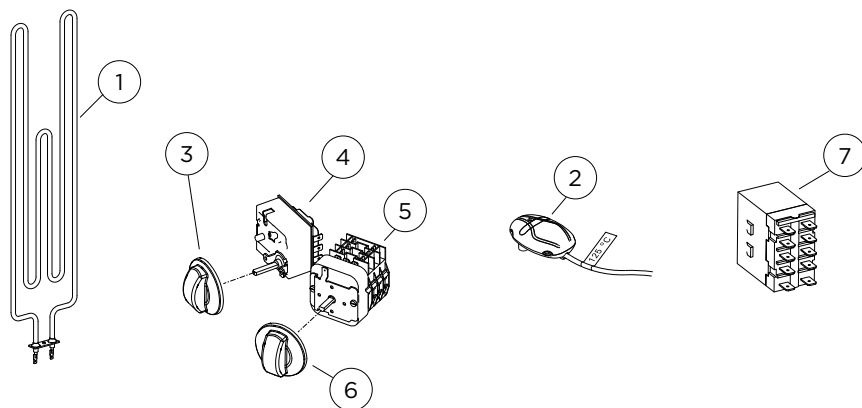



Cilindro XE/XW

PC70(XE/XW) 6.8 kW / PC90(XE/XW) 9.0 kW

Iitm.Nr. HPC7004MXE, HPC704XE, HPC9004MXE, HPC904XE

No.	Name	Type	Item code	pcs
1	Heater element 2260 W x 3	70XE, 70XW	SPZRH-720	
1	Heater element 3000 W x 3	90XE, 90XW	SPZSE-259	
2	Circuid board		SP683	
3	Control panel	70XE, 90XE	SP380	
4	Control panel	70XW, 90XW	SP694 (Wifi)	
5	Temperature sensor 125 °C		SP248	
6	Main switch		SPZSK-684	
7	Datacable 5 m		SP311	
8	Wall bracket PC		SP615	
9	Support top plate		SPZSC-135	
10	Adjustable leg (set of 4 pcs)		SPZSA-442	

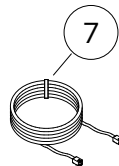
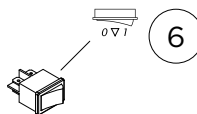
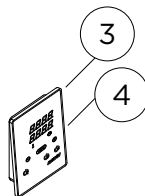
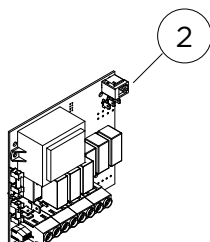
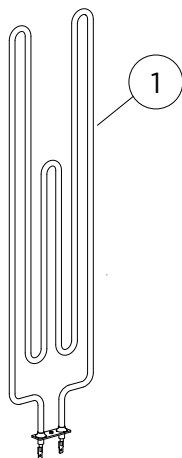



Cilindro Plus

PP70(E/SP) 6.8 / PP90(E/SP) 9.0 kW

Itm.Nr. HPP700400SP, HPP900400SP, HPP700400, HPP900400, HPP700400E, HPP900400E

No.	Name	Type	Item code	pcs
1	Heating element 2260W / 230V	PP70/-E/-SP	SPZRH-720	3
	Heating element 3000W / 230V	PP90/-E/-SP	SPZSE-259	3
2	Temperature sensor (125°C limiter)	PP-E	SP248	
3	Thermostat knob	PP, PP-SP	SPZWA-021	
4	Thermostat overheating limiter switch	PP, PP-SP	SPZSK-520	
5	Timer 4+8h	PP	SPZSK-510	
6		PP	SP654	
7		PP90	SP207	
8	Pilot lights, red	PP, PP-SP	SPZWA-061	
9		PP-SP	SP663	

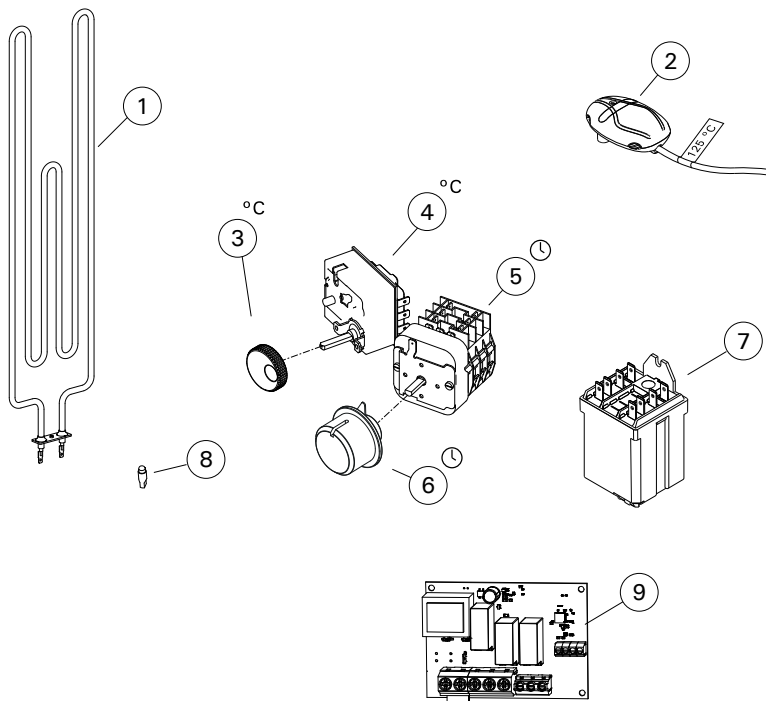



Cilindro Pro

PC100E/135E 13.2 kW / PC165E/200 19.8 kW

Itm.Nr. HPCE100400, HPCE165400, HPCE100400M, HPCE165400M

No.	Name	Type	Item code	pcs
1	Heating element 2200 W / 230 V	PC100E/135E PC165E/200E	SPZSC-022	6 9
2	Wiring harness	PC100E/135E	SPZSC-716	1
3	Wiring harness	PC165E/200E	SPZSC-766	1
4	Temperature sensor		SP247	1

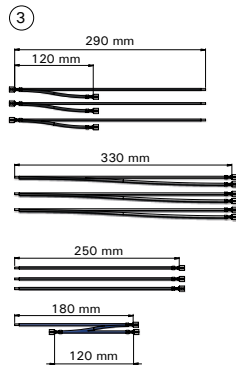
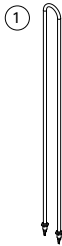

How to replace the heating elements?





Cilindro (USA/CANADA)

PC60E 6.0 kW / PC70E 7.0 kW / PC80E 8.0 kW / PC90E 9.0 kW / PC110E 10.5 kW

Itm.Nr. HPCS6U1H, HPCS7U1H, HPCS8U1H, HPCS8U3H, HPCS9U1H, HPCS11U1H, HPCS11U3H

No.	Name	Type	Item code	pcs
1	Heater element 2000 W/240 V	HPCS6U1H	SPY10-0018	3
1	Heater element 2250 W/240 V	HPCS7U1H	SPY10-0005	3
1	Heater element 2650 W/240 V	HPCS8U1H	SPY10-0017 / SPY10-0017I	3
1	Heater element 3000 W/240 V	HPCS9U1H	SPY10-0004	3
1	Heater element 3500 W/240 V	HPCS11U1H	SPY10-0002	3
1	Heater element 2650 W/208 V	HPCS8U3H	SPY10-0019	3
1	Heater element 3500 W/208 V	HPCS11U3H	SPY10-0001	3
2	Overheat protector		SPZSK-765	1
3	Temperature sensor		SP248	1
4	Adjustable leg (set of 4 pcs)		SPZSA-442	1

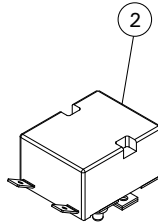
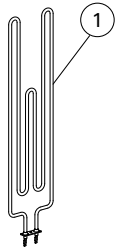

4





Cilindro (USA/CANADA)

PC60 6.0 kW / PC70 7.0 kW / PC80 8.0 kW / PC90 9.0 kW / 10.5 kW

Itm.Nr. HPCS6U1HB, HPCS8U1HB, HPCS9U1HB, HPCS7U3HB, HPC9U3HB, HPC7U1HB, HPC7U3HB, HPCS9U3HB

No.	Name	Type	Item code	pcs
1	Heater element 2000 W/240 V	HPCS6U1HB	SPY10-0018	3
1	Heater element 2250 W/240 V	HPCS7U1HB	SPY10-0005	3
1	Heater element 2650 W/240 V	HPCS8U1HB	SPY10-0017 / SPY10-00171	3
1	Heater element 3000 W/240 V	HPCS9U1HB	SPY10-0004	3
2	Overheat protector		SPZSK-764	1
3	Timer		SPZSK-766	1
4	Thermostat		SPZSK-762	1
5	Contactur		SPZSK-778	1
6	Adjustable leg (set of 4 pcs)		SPZSA-442	1

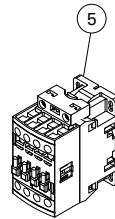
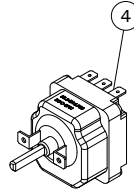
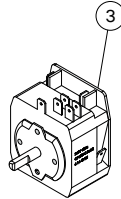
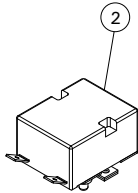
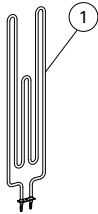

6





Club Combi

K10,5GS 10.5 kW / K15GS 15 kW / K13,5GS 13.5 kW

Itm.Nr. HRKG110400S, HRKG135400S, HRKG150400S

No.	Name	Type	Item code	pcs
1	Evaporator heating element 2000 W/230 V		SPZH-104	1
2	Watertank	K10,5GS-K15GS	SPZSL-795B	1
3	Tap R 1/4		SPZH-130	1
4	Overheating limiter, combi heaters		SPZSK-764	1
5	Thermostat 110 °C		SPZSN-250	1
6	Soapstone cup ø 46/36		SPZH-205	1
7	Solenoid valve 230VAC		SPZSS-610	1
8	Heating element 1500W 230V	K10,5GS	SPZSS-110	3
9	Heating element 2000W 230V	K13,5GS	SPZSS-120	3
		K10,5GS		3
10	Heating element 2500W 230V	K13,5GS	SPZSP-250	3
		K15GS		6

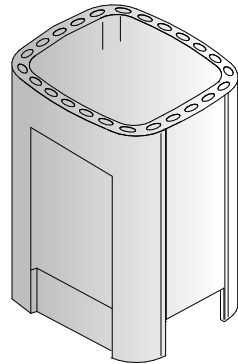
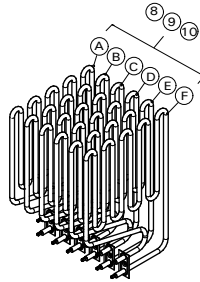
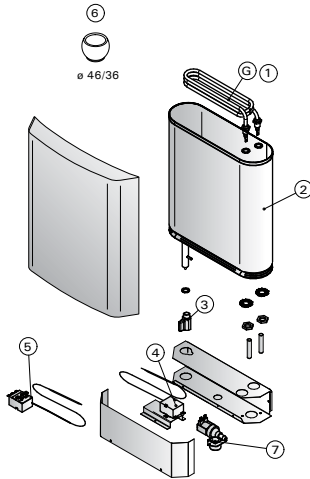

POWER TYP	POWER							TOTAL POWER STEAMER OFF	TOTAL POWER STEAMER ON
	A	B	C	D	E	F	G		
K10.5GS	1500	2000	1500	2000	1500	2000	2000	10.5kW	10.5kW
K13.5GS	2500	2000	2500	2000	2500	2000	2000	13.5kW	13kW
K15GS	2500	2500	2500	2500	2500	2500	2000	15kW	14.5kW





Club

K11G 11kW / K13,5G 13.5kW / K15G 15 kW

Itm.Nr. HRKG110400, HRKG135400, HRKG150400, HRKG1002, HRKG1202, HRKG1502

No.	Name	Type	Item code	pcs
1	Heating element 2150W 230V	K11G	SPZSP-240	
2	Harvia Heating element 1500W 230V	K11G	SPZSS-110	
3	Heating element 2000W 230V	K13,5G	SPZSS-120	
4	Heating element 2500W 230V	K13,5G, K15G	SPZSP-250	

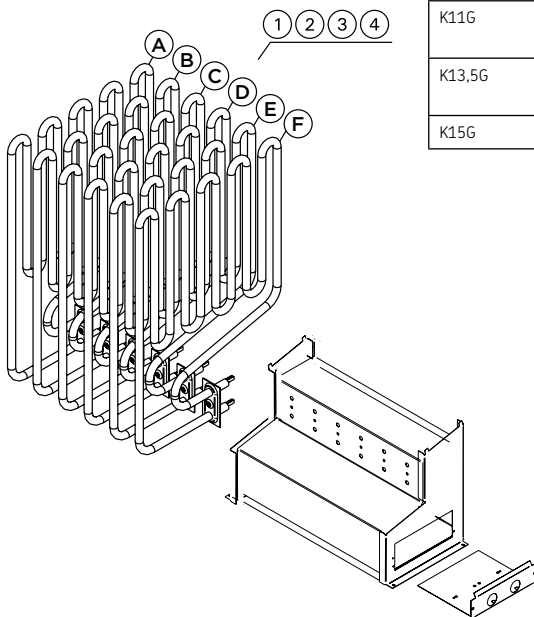

K11G	A, C, E B, D, F	2150 W/230 V 1500 W/230 V
K13,5G	A, C, E B, D, F	2000 W/230 V 2500 W/230 V
K15G	A, B, C, D, E, F	2500 W/230 V





Club (USA/CANADA)

K10G-U1 10 kW / K12.5G-U1 12.5 kW / K15G-U1 15 kW / K10G-U3 / K12.5G-U3 12.5 kW / K15G-U3 15 kW / K10G-U1W 10 kW/ K12.5G-U1W 12.5 kW / K15G-U1W 15 kW / K10G-U3W 10 kW / K12.5G-U3W 12.5 kW / K15G-U3W 15 kW

Itm.Nr. HRKGU102083, HRKGU10240, HRKGU1020C1, HRKGU1024C, HRKGU122083, HRKGU122401, HRKGU1220C, HRKGU1224C, HRKGU152083, HRKGU152401, HRKGU1520C, HRKGU1524C, HRKGU102401

No.	Name	Type	Item code	pcs
1	Heating element 1640 W / 240 V	K10G-U1 / K10G-U1W K12.5G-U1 / K12.5G-U1W	SPZSS-110U	6 (A, B, C, D, E, F) 3 (A, C, E)
1	Heating element 2350 W / 240 V	K12.5G-U1 / K12.5G-U1W K15G-U1 / K15G-U1W	SPZSP-240I	3 (B, D, F) 6 (A, B, C, D, E, F)
1	Heating element 1640 W / 208 V	K10G-U3 / K10G-U3W	SPZSS-120U	6 (A, B, C, D, E, F)
1	Heating element 2050 W / 208 V	K12.5G-U3 / K12.5G-U3W	SPZSP-250U	6 (A, B, C, D, E, F)
1	Heating element 2460 W / 208 V	K15G-U3 / K15G-U3W	SPZSP-255	6 (A, B, C, D, E, F)
2	Protective grille		SPKGG-100	
3	Overheating limiter / switch		SPZSK-765	
4	Adjusting leg		SPZSA-442	
	Wireset 240 V 1-phase heaters		SPZSL-930	
	Wireset 208 V 3-phase heaters		SPZSL-935	

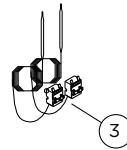
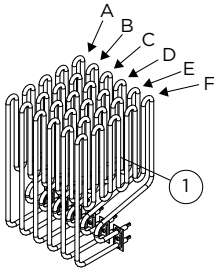

**Delta****D23 2.3 kW / D36 3.6 kW****Itm.Nr. HD234M, HDE234M, HD294M, HDE294M, HD364M, HDE364M**

No.	Name	Type	Item code	pcs
1	Heating element 1800 W / 230 V	D29/D29E x1 D36/D36E x2	SPZSN-160	
1	Heating element 1150 W / 230 V	D23/D23E x2 D29/D29E x1	SPZSN-150	
2	Timer		SPZSK-510	
3	Thermostat		SPZSK-520	
4	Thermostat knob		SPZST-220	
5	Timer knob		SPZST-230	

**Series 100****ST136(B/BE) 3.6 kW****Itm.Nr. ST1364B, ST1364BE**

No.	Name	Type	Item code	pcs
1	Heating element 1800 W / 230 V	136, 136E	SPZSN-160	
2	Timer	136	SPZSK-510	
3	Thermostat	136	SPZSK-520	
4	Thermostat knob	136	SPZST-220	
5	Timer knob	136	SPZST-230	

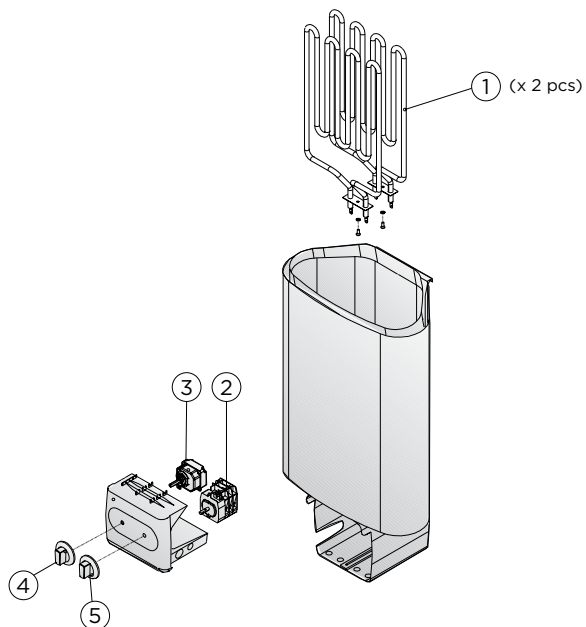



Delta (JAPAN)

D36 2.7 kW

Itm.Nr. HD272M

No.	Name	Type	Item code	pcs
1	Heating element		SPZSN-160	2
2	Timer		SPZSK-510-4	
3	Thermostat		SPZSK-520	
4	Thermostat knob		SPZST-220	
5	Timer knob		SPZST-230-4	

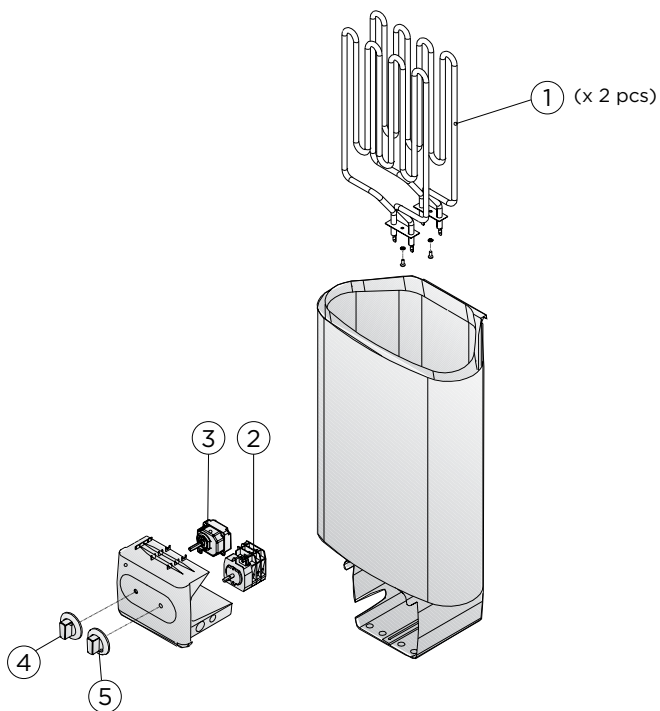



Figaro

FG70(E) 6.8 kW / FG90(E) 9.0 kW

Itm.Nr. HFG700400M, HFG700400M, HFGE700400M, HFGE900400M, HFG700400V, HFG900400V, HFGE700400V, HFGE900400V

No.	Name	Type	Item code	pcs
1	Heating element 2260 W	FG70, FG70E	SPZRH-720	
2	Heating element 3000 W	FG90, FG90E	SPZSE-259	
3	Thermostat	FG70, FG90	SPZSK-520	
4	Timer	FG70, FG90	SPZSK-510	
5	Thermostat switch	FG70, FG90	SPZST-220	
6	Timer switch	FG70, FG90	SPZST-230	
7	Contactor 1 3-phase	FG90	SP225	

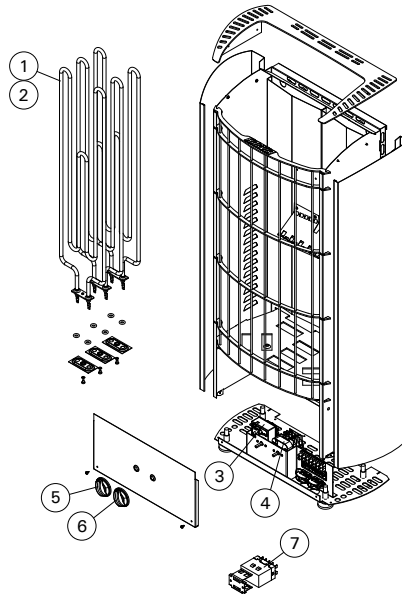

REPLACING THE THERMOSTAT

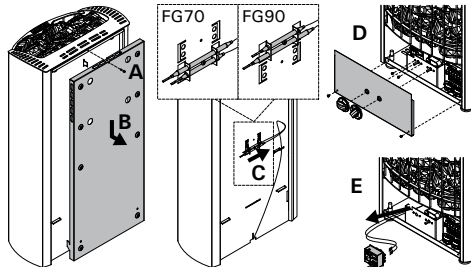

**Forte****AFB40 4 kW / AFB60 6.0 kW / AFB90 9.0 kW****Itm.Nr. HAFB400400M, HAFB400400S, HAFB600400M, HAFB600400S, HAFB900400M, HAFB900400S**

No.	Name	Type	Item code	pcs
1	Gasket		SPZSF-230	
2	Control panel		SP611	
3	Heater element	AFB4	SPZSF-20U	3
3	Heater element	AFB6	SPZSF-30	3
3	Heater element	AFB9	SPZSF-50	3
4	Overheat limiter switch		SPZSF-710	
5	Contacttor K1		SP207	
6	Contctor K2		SP208	
7	ON/OFF electric switch		SPZSK-684	
8	Power electronic without display		SP612	
9	Repair set for hinges		SP260	
10	Data cable 5m		SP311	
10	Data cable 10m		SP315	
11	Hatch		SP272	

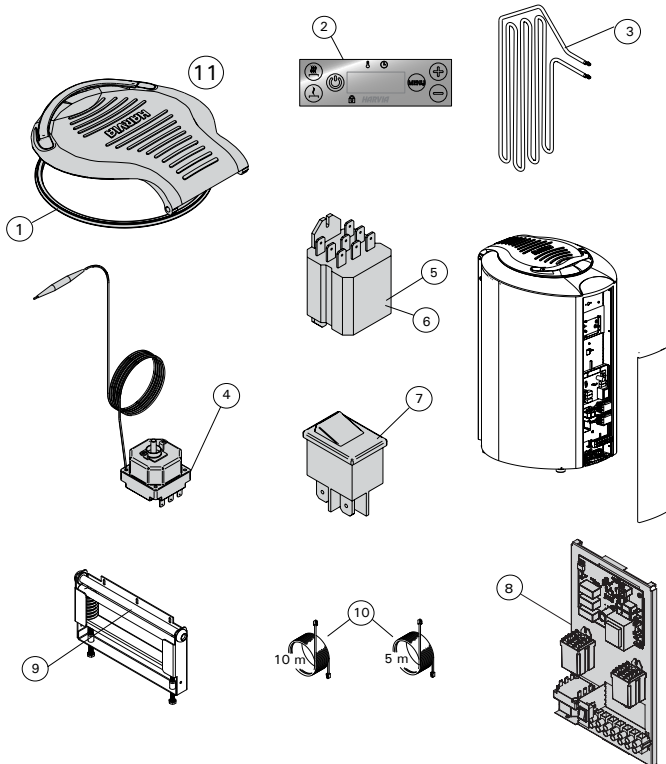



Glow

TRT70XE 6.8 kW / TRT90XE 9.0 kW)

Itm.Nr. HTRT704XE, HTRT904XE

No.	Name	Type	Item code	pcs
1	Heater element (2260 W)	TRT70XE	SPZRH-720	3
2	Heater element (3000 W)	TRT90XE	SPZSE-259	3
3	Temperature sensor (125 °C)		SP248	
4	Circuit board		SP683	
5	Control panel		SP380	
6	Data cable, 5 m		SP311	
7	Power switch and cover, white		SPZSK-684	

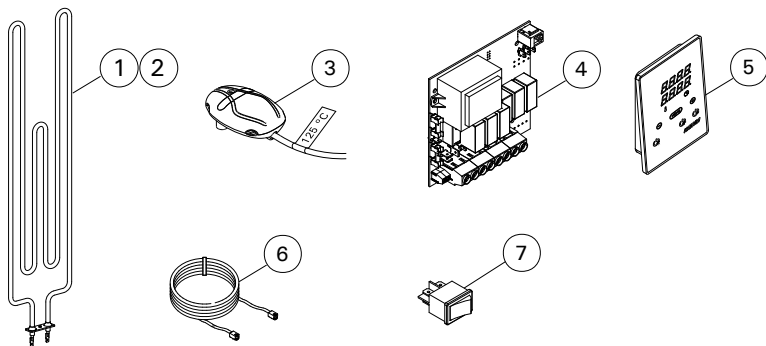



Glow Corner

TRC70 6.8 kW / TRC90 9.0 kW

Itm.Nr. HTRC700400, HTRC900400

No.	Name	Type	Item code	pcs
1	Heater element (2260 W)	TRC70	SPZRH-720	3
1	Heater element (3000 W)	TRC90	SPZSE-259	3
2	Thermostat knob		SPZST-220	
3	Thermostat		SPZSK-520	
4	Timer		SPZSK-510	
5	Timer knob		SPZST-230	
6	Contactors	TRC90	SP207	

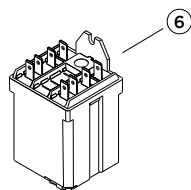
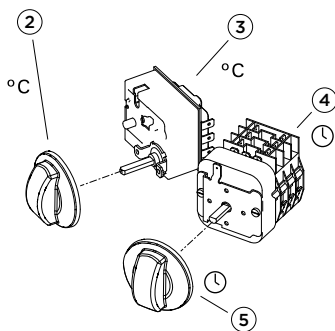
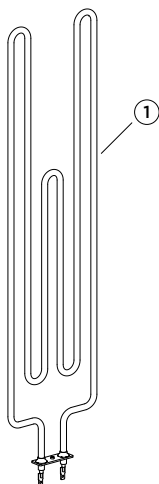



KIP (JAPAN)

KIP60E 5,5 kW 200 V / KIP80E 7,4 kW 200 V

Itm.Nr. HEK602S, HEK602M, HEK802S, HEK802M

No.	Name	Type	Item code	pcs
1	Heating element 2000 W / 208 V	HEK602S/M	SPZSK-742I	
2	Heating element 2670 W / 208 V	HEK802S/M	SPZSK-745I	

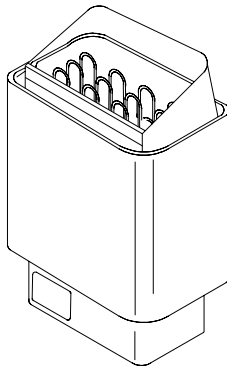
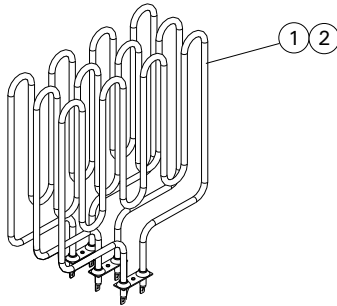



KIP

KIP45(E) 4.5 kW / KIP60(E) 6.0 kW / KIP80(E) 8.0 kW / KIP90(E) 9.0 kW)

Itm.Nr.HBK450230, HBK600230, HBK800230, HBK450230S, HBK600230S, HBK800230S, HBK900230S, HBK900230, HEK900230, HEK900230S, HEK800230, HEK800230S, HEK450230, HEK450230S, HEK450230, HEK600230S, HEK600230



Sähköri

KIP60 6.0 kW / KIP80 8.0 kW

HBH600400, HBH800400, HBH450400, HBH600400ST, HBH800400ST

No.	Name	Type	Item code	pcs
1	Heater element 1500 W / 230 V	45/E	SPZSK-690	
2	Heater element 2000 W / 230 V	60/E	SPZSK-700	
3	Heater element 2670 W /230 V	80/E	SPZSK-710	
4	Heater element 3000 W / 230 V	90/E	SPZSK-720	
5	Timer 4+8h		SPZSK-510	
6	Thermostat overheating limiter switch		SPZSK-520	

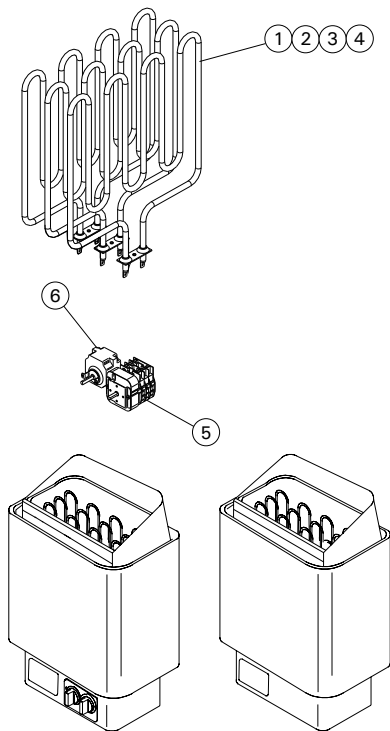



KIP (USA/CANADA)

**KIP-30-B1 3.0 kW 240V / KIP-45-B1 4.5 kW 240V / KIP-60-B1 6.0 kW 240V / KIP-80-B1 8.0 kW 240V /
 KIP-30-B3 3.0 kW 208V / KIP-45-B3 4.5 kW 208V / KIP-60-B3 6.0 kW 208V / KIP-80-B3 8.0 kW 208V**
Itm.Nr. KIP-30-B1, KIP-45-B1, KIP-60-B1, KIP-80-B1, KIP-30-B3, KIP-45-B3, KIP-60-B3, KIP-80-B3

No.	Name	Type	Item code	pcs
1	Heater element 1000 W / 240V	KIP-30-B1	SPZSK-725	3
2	Heater element 1500 W / 240V	KIP-30-B3 KIP-45-B1	SPZSK-310	3
3	Heater element 1500 W / 208 V	KIP-45-B3	SPZSK-738	3
4	Heater element 2000 W / 240 V	KIP-60-B1	SPZSL-313	3
5	Heater element 2000 W / 208 V	KIP-60-B3	SPZSK-742	3
6	Heater element 2670 W / 240 V	KIP-80-B1	SPZSL-316I	3
7	Heater element 2670 W / 208 V	KIP-80-B3	SPZSK-745I	3
8	Thermostat		SPZSK-762	1
9	Timer		SPZSK-766	1
10	Overheating limiter/switch		SPZSK-765KIP	1
11	Contactor		SPZSK-778	1
12	Protective grille		SPZSK-683	1
13	Wooden strips		SPZSM-230	1
14	Knob		SPZSF-400	2

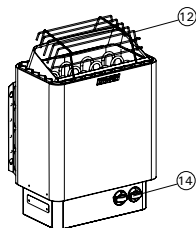

SPZSK-725

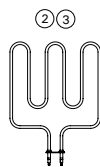

SPZSK-310
SPZSK-738

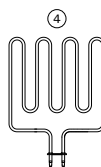

SPZSL-313

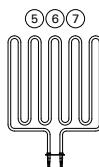

SPZSK-742
SPZSK-745I
SPZSL-316I

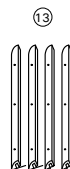
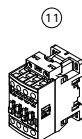
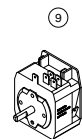
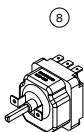



Kivi

PI70 6.9 kW / PI90 9.0 kW

Itm.Nr. HPI700400, HPIE700400, HPI900400, HPIE900400

No.	Name	Type	Item code	pcs
1	Heater element 2300 W	PI70, PI70E	SPZRH-247	
2	Heater element 3000 W	PI90, PI90E	SPZRH-249	
3	Temperature sensor 125 °C		SP248	
4	Main switch		SPZSK-684	
5	Power Unit SET Kivi EE/XE	PI70, PI90	SPZRH-309XE	

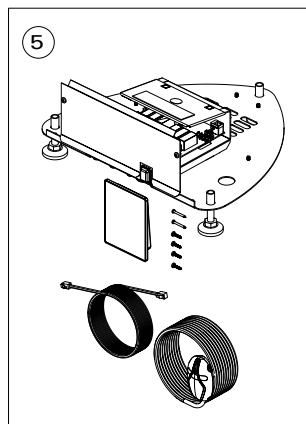
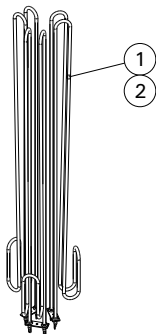
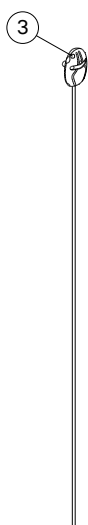



Legend (E/XW)

PO70(E/XW) 6.8 kW / PO110(E/XW) 10.8 kW

Itm.Nr. HPOE704, HPOE1104, HPO704XW, HPO1104XW

No.	Name	Type	Item code	pcs
1	Heater element 3600 W	PO110XE, PO110E	SPZSC-360	
1	Heater element 2260 W	PO70XE, PO70E	SPZRH-720	
2	Temperature sensor 125 ° C		SP248	
3	Circuid board	PO70XE, PO110XE	SP683	
4	Display board	PO70XE, PO110XE	SP380	
5	Datacable 5m	PO70XE, PO110XE	SP311	
5	Datacable 1,5m	PO70XE, PO110XE	SP312	
5	Datacable 10m	PO70XE, PO110XE	SP315	
6	Main switch	PO70XE, PO110XE	SPZSK-684	

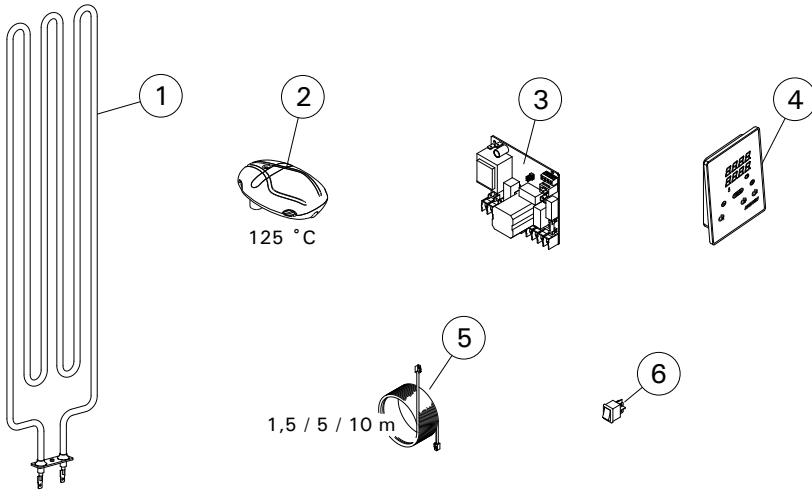



Legend (FC)

PO70FC 6.8 kW / PO110FC 10.8 kW

Itm.Nr. HPO704FC, HPO1104FC

No.	Name	Type	Item code	pcs
1	Heater element 3600 W	PO110XE, PO110E	SPZSC-360	
1	Heater element 2260 W	PO70XE, PO70E	SPZRH-720	
2	Temperature sensor 125 ° C		SP248	
3	Circuid board	PO70XE, PO110XE	SP683	
4	Datacable 5m	PO70XE, PO110XE	SP311	
4	Datacable 1,5m	PO70XE, PO110XE	SP312	
4	Datacable 10m	PO70XE, PO110XE	SP315	
5	Main switch	PO70XE, PO110XE	SPZSK-684	
6	Fenix FX110 Control panel core		SP392	1
7	Fenix FX110 backplate + mounting kit		SP393	1

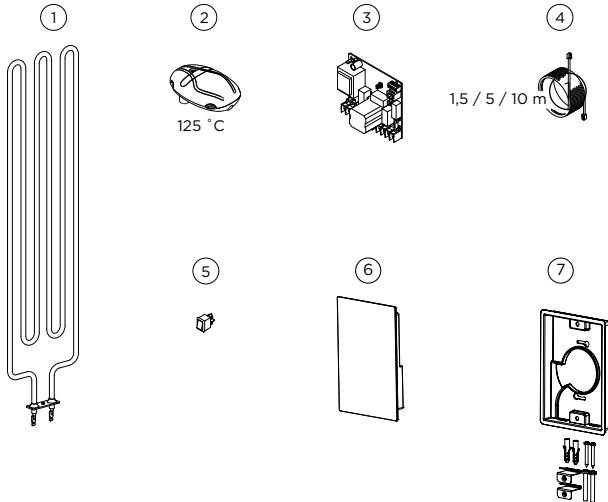



Legend Pro

PO11E 11 kW / PO165E 16.5 kW

Itm.Nr. HPO110400M, HPO165400

No.	Name	Type	Item code	pcs
1	Heater element 2150 W 230 V	PO11	SPZSP-240	3 (A, B, F)
1	Heating element 1500W 230V	PO11	SPZSS-110	3 (C, D, E)
1	Heating element 3000W 230V	PO165	SPZSP-255	3 (A, B, F)
1	Heating element 2500W 230V	PO165	SPZSP-250	3 (C, D, E)

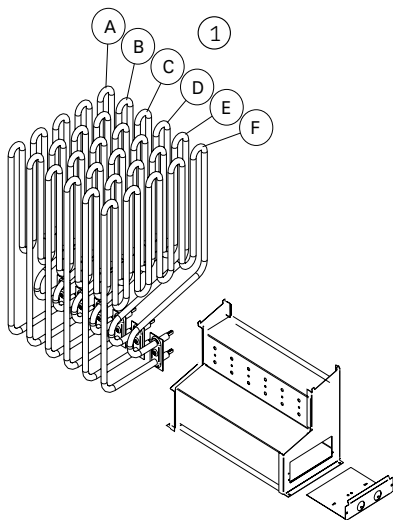



Moderna XE

V45XE 4.5 kW / V60XE 6.0 kW / V80XE 8.0 kW

Itm.Nr. HVE454XEM, HVE604XEM, HVE804XEM

No.	Name	Type	Item code	pcs
1	Heater element 1500 W / 230 V	V45XE	SPZSK-690	3
2	Heater element 2000 W / 230 V	V60XE	SPZSK-700	3
3	Heater element 2670 W / 230 V	V80XE	SPZSK-710	3
4	Temperature sensor 135°C		SP247	
5	Circuit board		SP683	
6	Control panel		SP380	
7	ON/OFF electric switch		SPZSK-684	
8	Data cable 5 m		SP311	

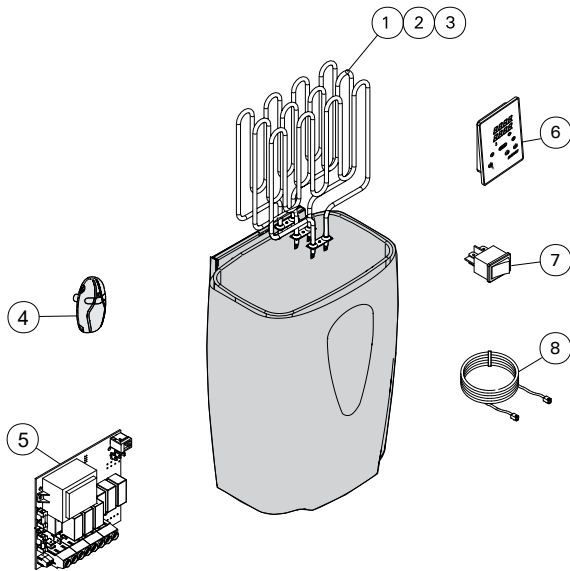



Modulo Alto

MDA165/200G 16.6 kW / 19.8 kW

Itm.Nr. HMDA1654G, HMDA1654GL, HMDA1654GR, HMDA1654C

No.	Name	Type	Item code	pcs
1	Heating element 2200 W / 230 V		SPZSC-022	
2	Temperature sensor (135°C limiter)		SP255	

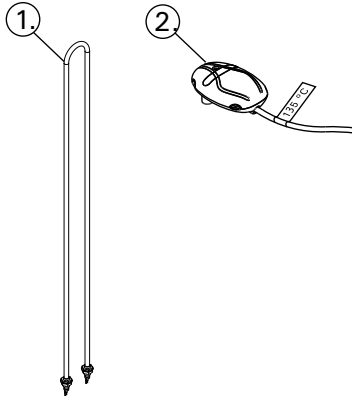

How to replace the heating elements?





Modulo

MD135(G/GR/GL/H) 13.6 kW / 160(G/GR/GL/H) 15.8 kW / 180(G/GR/GL/H) 18 kW

Itm.Nr. HMD135400, HMD1354H, HMD1354GL, HMD1354GR, HMD1354G, HMD160400, HMD1604H,

HMD1604GR, HMD1604GL, HMD1604G, HMD180400, HMD1804H, HMD1804GR, HMD1804GL, HMD1804G

No.	Name	Type	Item code	pcs
1	Heating element 2260 W / 230 V	13.6 kW	SPZCU-823	6
1	Heating element 2260 W / 230 V	15.8 kW	SPZCU-823	3 (B, D, F)
2	Heating element 3000 W / 230 V	15.8 kW	SPZCU-830	3 (A, C, E)
2	Heating element 3000 W / 230 V	18 kW	SPZCU-830	6

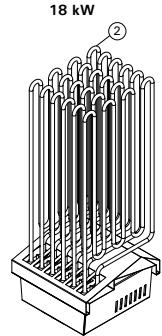
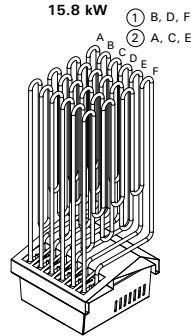
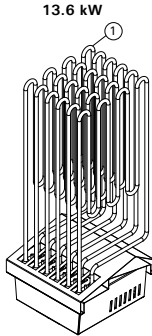
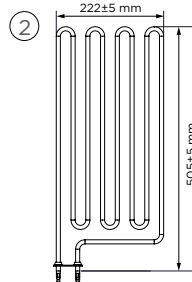
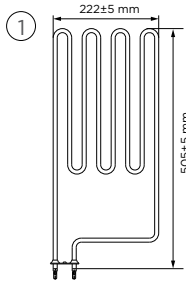
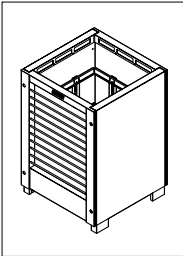
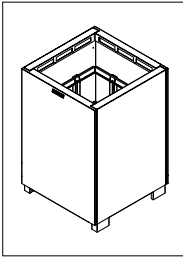

How to replace the heating elements?



**Qube****9.0 / 10.5 kW****Itm.Nr. QUBE-090, QUBE-105**

No.	Name	Type	Item code	pcs
	Heater element	QUBE-90	SPSEN-002	6
	Heater element	QUBE-105	SPSEN-002	3
			SPSEN-003	3

**Qube****12.0 / 15.0 kW****Itm.Nr. QUBE-120, QUBE-150**

No.	Name	Type	Item code	pcs
	Heater element	QUBE-120	SPSEN-002	6
			SPSEN-005	3
	Heater element	QUBE-150	SPSEN-002	6
			SPSEN-003	3





Qube Combi

QU100S 10kW / QU135S 13.5 kW / QU160S 16 kW

Itm.Nr. HQU1004CM, HQU1354CM, HQU1604CM

No.	Name	Type	Item code	pcs
1	Soapstone cup		SPZH-205	
2	Steam grate		SPZSQ-010	
3	Water level plate		SPZSQ-018	
4	Water tank (large)		SPZSQ-013	
5	Water tank (for float valve)		SPZSQ-016	
6	Water tube set		SPO020	
7	Discharge valve, manual		SPZG-575	
8	Adjustable leg, M10 x 40 mm Stainless steel		SPY06-0088	
9	Heating elements 1500 W	QU100S	SPSEN-002	2
		QU135S		8
		QU160S		2
10	Heating elements 2000 W	QU100S	SPSEN-003	3
		QU160S		6
11	Wire set	QU100S	SPZSQ-045	
12	Wire set	QU135S QU160S	SPZSQ-030	
13	Steam tube set		SPO011	
14	Steam generator 3 kW		SPY07-0037	
15	Float valve		SPY07-0038	

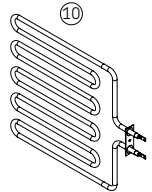
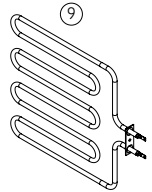
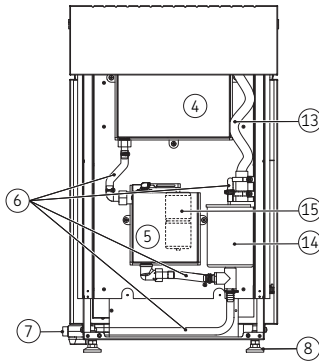
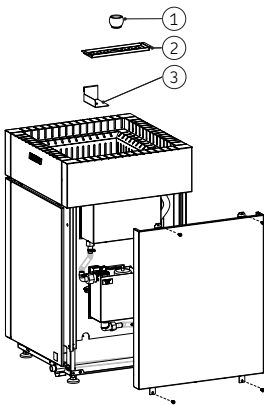

How to replace the heating elements?





Qube Pro

240 18-24 kW / Qube Pro 360 30-36 kW

Itm.Nr. QUBE-240, QUBE-360

No.	Name	Type	Item code	pcs
1	Temperature sensor	QUBE-240	SP255	
1	Temperature sensor	QUBE-360	SP233	
2	Heater element	QUBE-240	SPSEN-003	
2	Heater element	QUBE-360	SPSEN-012	

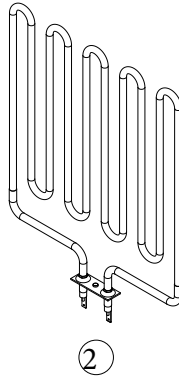

QUBE-240

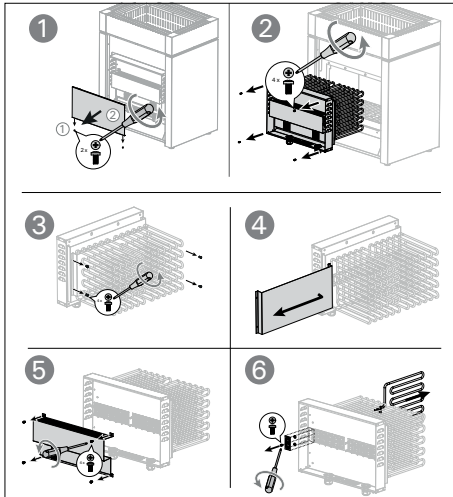

QUBE-360

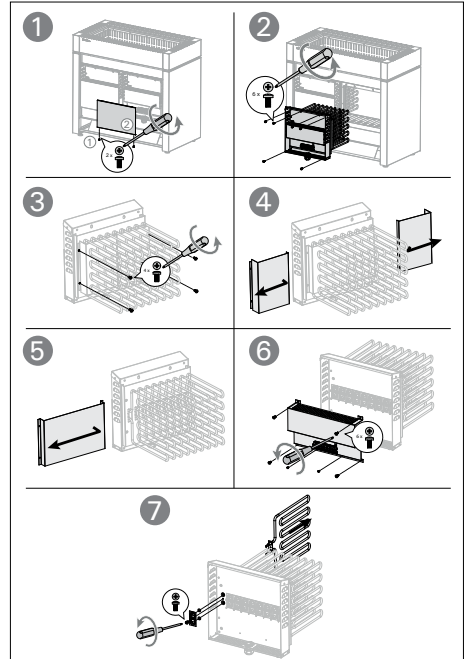



Series 100-200

ST145(B/BE) 4.5 kW / ST160(B/BE) 6.0 kW / ST180(B/BE) 8.0 kW / ST190(B/BE) 9.0 kW / ST245BE 4.5 kW / ST260BE 6.0 kW / ST290BE 9.0 kW

Itm.Nr. ST145400B, ST145400BE, ST160400B, ST160400BE, ST180400B, ST180400BE, ST190400B, ST190400BE, ST245400BE, ST260400BE, ST280400BE, ST290400BE

No.	Name	Type	Item code	pcs
1	Heating element 1500 W/230 V	145, 145E, 245E	SPZSK-690	
2	Heating element 2000 W/230 V	160, 160E, 260E	SPZSK-700	
3	Heating element 2670 W/230 V	180, 180E, 280E	SPZSK-710	
4	Heating element 3000 W/230 V	190, 190E, 290E	SPZSK-720	
5	Timer	145-190	SPZSK-510	
6	Thermostat	145-190	SPZSK-520	

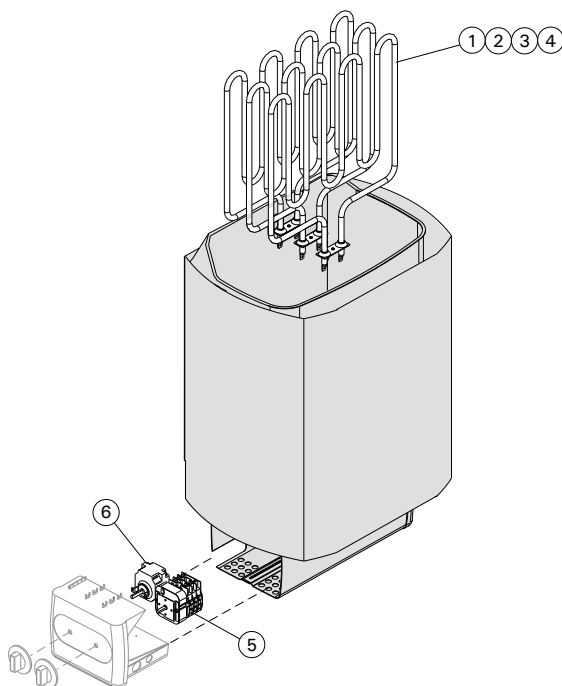



Spirit

SP60E 6.0 kW / SP90E 9.0 kW

Itm.Nr. HSPE604M, HSPE904M, HSP604MXW, HSP904MXW

No.	Name	Type	Item code	pcs
1	Heater element 2000 W	SP60E, SP60XW	SPY10-0015	
2	Heater element 3000 W	SP90E, SP90XW	SPZCU-830	
3	Temperature sensor 125 °C		SP248	

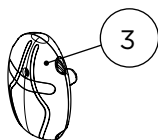
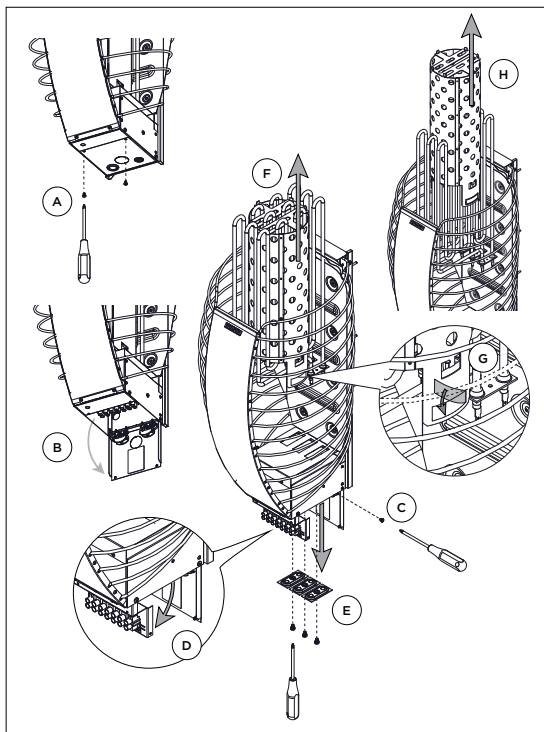
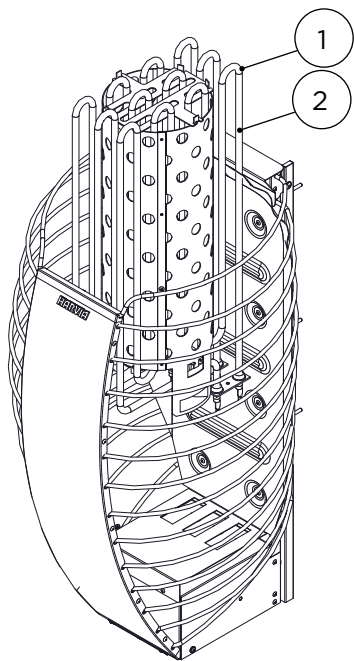



Spirit (JAPAN)

SP60E 6,0 kW 200V / SP90E 9,0 kW 200 V

Itm.Nr. HSPE602M, HSPE902M

No.	Name	Type	Item code	pcs
1	Heater element 2000 W		SPY10-0025I	
2	Heater element 3000 W		SPY10-0026I	
3	Temperature sensor 125 °C		SP248	

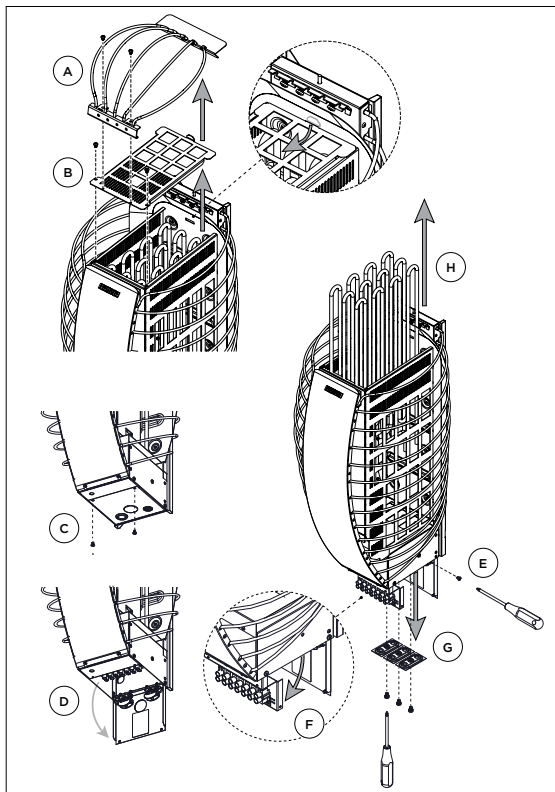
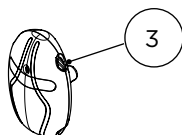
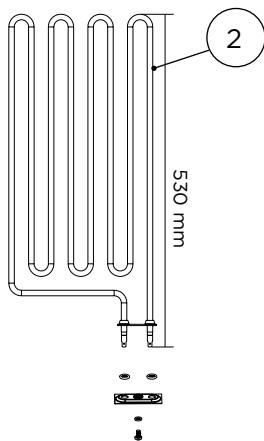
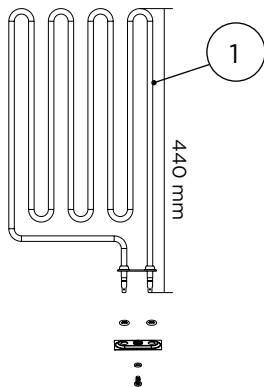



Spirit (USA/CANADA)

SP60E 6.0 kW 240V 1ph / SP80E 8.0 kW 240V 1ph / SP90E 9.0 kW 240V 1ph

Itm.nr. HSPE60U1M, HSPE80U1M, HSPE90U1M

No.	Name	Type	Item code	pcs
1	Heating element 2000 W / 240V	SP60E	SPY10-0021	3
2	Heating element 2650 W / 240V	SP80E	SPY10-0020	3
3	Heating element 3000W / 240V	SP90E	SPY10-0009SP	3
4	Electric set 240V		SPZHK-018	
5	Safety device switch set		SPZHK-036	
6	Temperature sensor 125 °C		SP248	

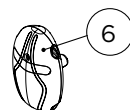
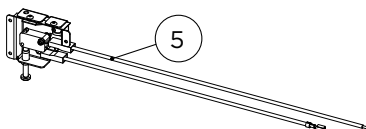
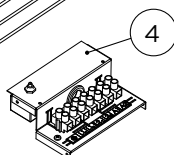
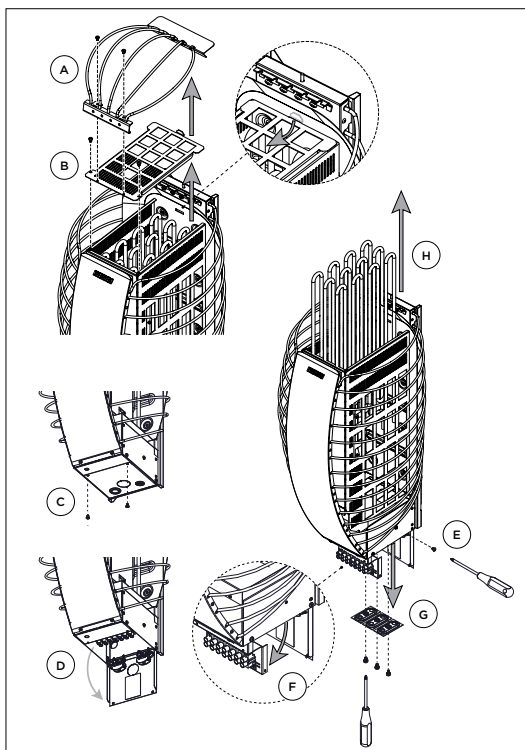
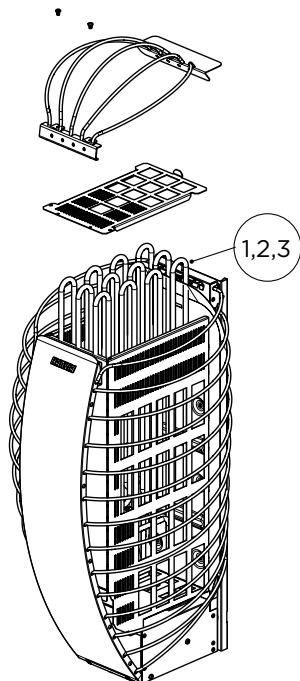



The Wall

SW45(E) 4.5 kW / SW60(E) 6.0 kW / SW90(E) 9.0 kW

Itm.Nr. HSWE450400, HSWE450400M, HSWE600400, HSWE600400M, HSWE900400, HSWE900400M, HSW450400, HSW450400M, HSW600400, HSW600400M, HSW800400, HSW800400M

No.	Name	Type	Item code	pcs
1	Heater element 1500 W	SW45/-E	SPY10-0016	
1	Heater element 2000 W	SW60/-E	SPY10-0015	
1	Heater element 2600 W	SW80	SPY10-0014	
1	Heater element 3000 W	SW90	SPZCU-830	
2	Heating element support		SPZWA-007	
3	Grid	SW	SPZWA-023	
3	Grid	SW E	SPZWA-077	
4	Knob for timer (Applies to heaters with serial numbers from 218000000 to 224020231, inclusive.)		SPZWA-011	
	Knob for timer (4h) (Applies to heaters with serial number 224020232 or later.)		SPZWA-011-4	
5	Lead through rubber		SPZWA-022	
6	Signal lamps		SPZWA-061	
7	Timer (Applies to heaters with serial numbers from 218000000 to 224020231, inclusive.)		ZSK-510	
	Timer (4h) (Applies to heaters with serial number 224020232 or later.)		ZSK-510-4	
8	Knob for thermostat		SPZWA-021	
9	Thermostate/overheating limiter		SPZSK-520	
10	Axel	SW45/SW60	SPZWA-041	
10	Axel	SW80/SW90	SPZWA-016	

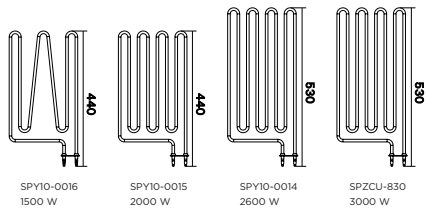
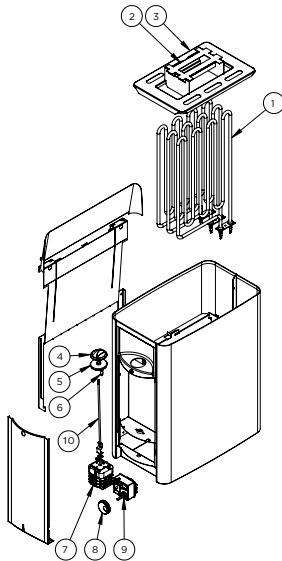

SPY10-0016
1500 W

SPY10-0015
2000 W

SPY10-0014
2600 W

SPZCU-830
3000 W

NOTE! Applies to heaters with serial number 224020232 or later.

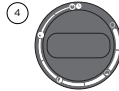

SPZWA-011-4

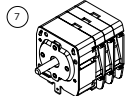

ZSK-510-4

NOTE! Applies to heaters with serial numbers from 218000000 to 224020231, inclusive.

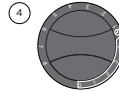

SPZWA-011

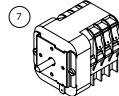

ZSK-510





The Wall (JAPAN)

SW45(E) 4.5 kW 200V / SW60(E) 6.0 kW 200V / SW90(E) 9.0 kW 200V

Itm.Nr. HSW452M, HSW602M, HSW902M, HSW452M, HSW602M, HSW902M

No.	Name	Type	Item code	pcs
1	Heater element 1500 W	SW45/-E	SPY10-0015	
1	Heater element 2000 W	SW60/-E	SPY10-0025I	
1	Heater element 3000 W	SW90/-E	SPY10-0026I	
2	Heating element support		SPZWA-007	
3	Grid	SW	SPZWA-023	
3	Grid	SW E	SPZWA-077	
4	Knob for timer		SPZWA-011-4	
5	Lead through rubber		SPZWA-022	
6	Pilot lights, red		SPZWA-061	
7	Timer and axel lock		SP641	
8	Knob for thermostat		SPZWA-021	
9	Thermostate		SPZSK-520	
10	Axel	SW45/SW60	SPZWA-041	
10	Axel	SW90	SPZWA-016	

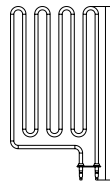
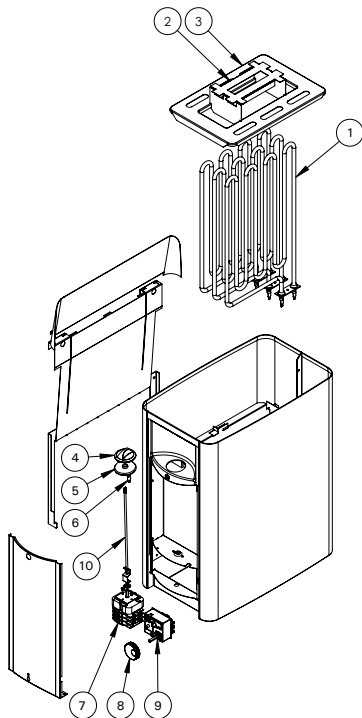

SPY10-0015
1500W

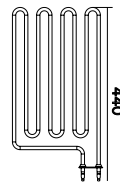

SPY10-0025I
2000W

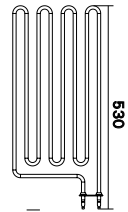

SPY10-0026I
3000W





The Wall (USA/CANADA)

SW60 6.0 kW 240V / SW80 8.0 kW 208V

Itm.Nr. HSW56U1B, HSW58U1B, HSW56U3B, HSW58U3B, HSW6U1B, HSW8U1B, HSW6U3B, HSW8U3B

No.	Name	Type	Item code	pcs
1	Heater element 2000 W / 240 V	HSWS6U1B	SPY10-0021	3
		HSW6U1B		3
1	Heater element 2650 W / 240 V 2000 W / 208 V	HSWS8U1B	SPY10-0020	3
		HSW8U1B		3
		HSWS6U3B		3
		HSW6U3B		3
1	Heater element 2650 W / 208 V	HSWS8U3B	SPY10-0022	3
		HSW8U3B		3
2	Overheat protector		SPZSK-764	1
3	Timer		SPZSK-766	1
4	Thermostat		SPZSK-762	1
5	Contactora		SPZSK-778	1
6	Element support		SPZWA-007	1
7	Steam guide		SPZWA-009	1
8	Knob for timer		SPZWA-027	1
9	Lead through rubber		SPZWA-022	1
10	Indicator lights		SPZWA-145	1
11	Axle		SPZWA-016	1
12	Thermostat knob		SPZWA-021	1
13	Safety guard		SPZWA-134	1

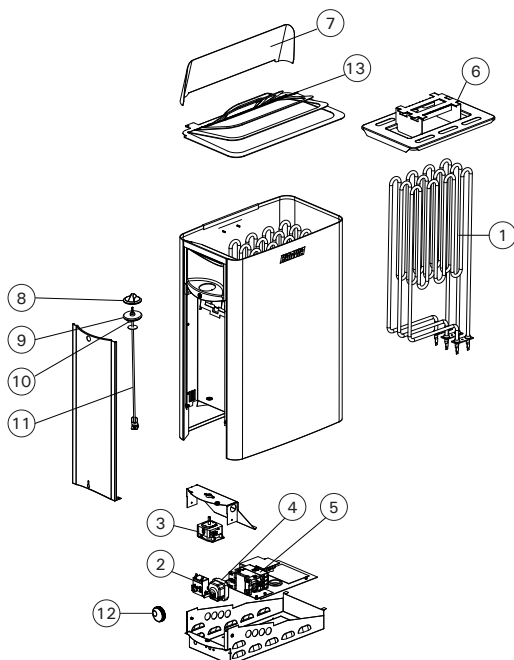



The Wall Combi

SW45S(A) 4.5 kW / SW70S(A) 7.0 kW / SW90S(A) 9.0 kW

Itm.Nr. HSW450400SA, HSW700400SA, HSW900400SA, HSW900400S, HSW450400S, HSW700400S

No.	Name	Type	Item code	pcs
1	Heating element, steam 2000 W / 230 V		SPZH-104	
2	Water reservoir		SPZSC-115	
3	Thermostat 110 °C		SPZSN-250	
4	Overheating limiter switch, Combi heaters		SPZSK-764	
5	Soapstone cup		SPZSS-505	
6	Silicone hose		SPZH-175	
7	Solenoid valve		SPZSS-610	
8	Heater element 2260 W / 230 V	SW45S/SA	SPZCU-823	2
	Heater element 2260 W / 230 V	SW70S/SA	SPZCU-823	3
	Heater element 3000 W / 230 V	SW90S/SA	SPZCU-830	3

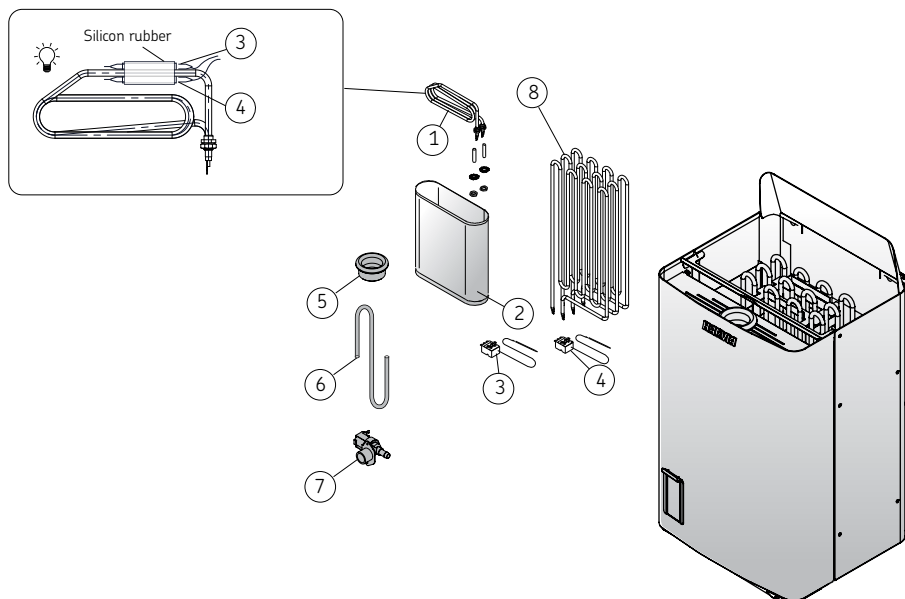



Vega

BC45(E) 4.5 kW / BC60(E) 6.0 kW / BC90(E) 9.0 kW

Itm.Nr. HCB450400S, HCB600400S, HCB800400S, HCB900400S, HCBE450400S, HCBE600400S, HCBE800400S, HCBE900400S

No.	Name	Type	Item code
1	Heating element 1500 W / 230 V		SPZSB-224
2	Heating element 2000 W / 230 V		SPZSB-226
3	Heating element 2670 W / 230 V		SPZSB-228
4	Heating element 3000 W / 230 V		SPZSB-229
5	Timer		SPZSK-511
6	Timer knob, black		SPZSB-125
7	Thermostat overheating limiter switch		SPZSK-520
8	Thermostat knob, black		SPZSB-115
9	Contactor 1/3-phase	BC90	SP225

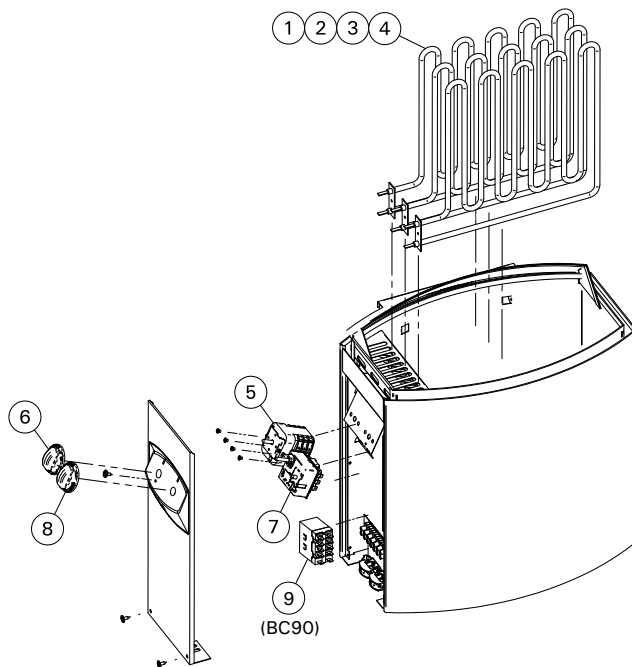



Vega Compact

BC23(E) 2.3 kW / BC35(E) 3.5 kW

Itm.Nr. HCB230400S, HCB350400S, HCBE230400S, HCBE350400S

No.	Name	Type	Item code	pcs
1	Heating element 1150 W / 230 V	BC23/E	SPZSB-770	2
2	Heating element 1150 W / 230 V	BC35/E	SPZSB-770	3
3	Timer		SPZSK-510	
4	Timer knob, black		SPZSB-125	
5	Thermostat overheating limiter switch		SPZSK-520	
6	Thermostat knob, black		SPZSB-115	
7	Pilot light		SPZSI-240	

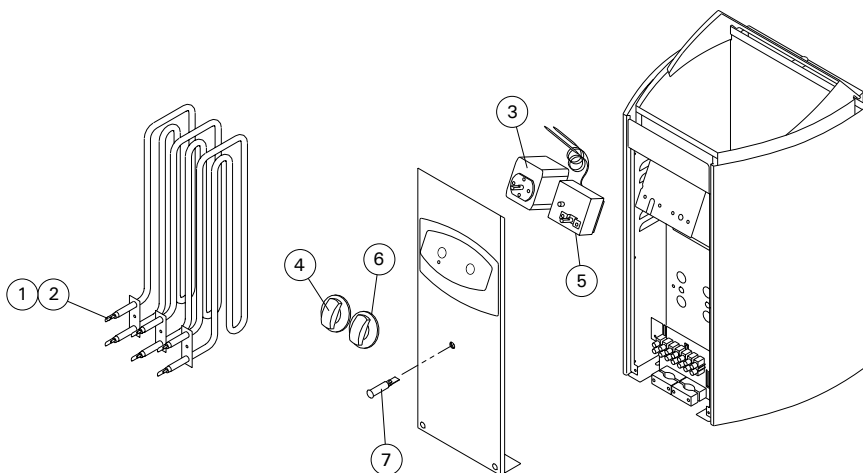



Vega Compact (USA/CANADA)

1.7 kW / 1.9 kW / 3.5 kW

Itm.Nr. HCBU1912241, HCBU352401, HCBU1712241

No.	Name	Type	Item code	pcs
1	Heating element 850 W / 120 V	HCBU1712241	SPZSB-774	2
	Heating element 950 W / 120 V	HCBU1912241	SPZSB-772	2
	Heating element 1150 W / 240 V	HCBU352401	SPZSB-773	3
2	Overheat protector		SPZSV-330	1
3	Timer 1h 120V		SPY07-0018	1
4	Thermostat US		SPZSK-762	1
5	Wirewound resistor 5,6kOhm / 5 W		SPY07-0017	1
6	Signal light for Vega Compact		SPZSI-240	1

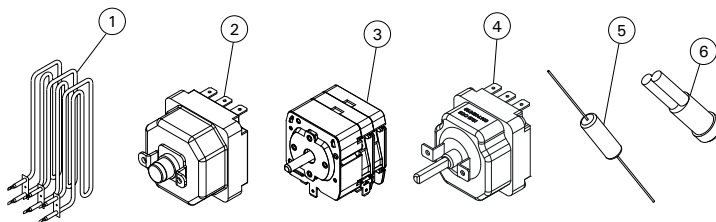



Vega Pro

BC105 10.5 kW / BC135 13.5 kW / BC165 16.5 kW

Itm.Nr. HCB105400S, HCB135400S, HCB165400S

No.	Name	Type	Item code	pcs
1	Heating element 1750 W / 230 V	BC105	SPZSB-461	6
	Heating element 1750 W / 230 V	BC135	SPZSB-461	3
	Heating element 2750 W / 230 V		SPZSB-462	3
	Heating element 2750 W / 230 V	BC165	SPZSB-462	6

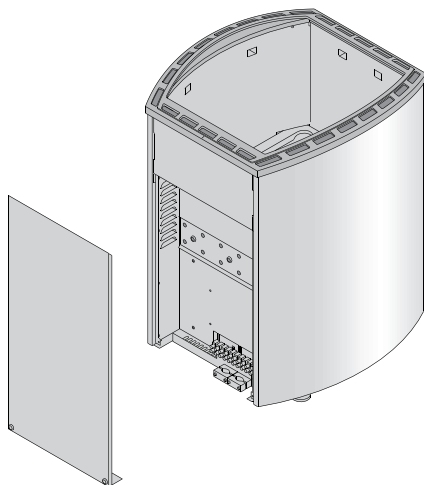
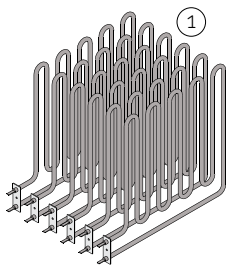



Virta Combi

HL70S(A) 7 kW / HL90S(A) 9 kW / HL110S(A) 11 kW

Itrm.Nr. HL700400S, HL900400S, HL110400S, HL700400SA, HL900400SA, HL110400SA

No.	Name	Type	Item code	pcs
1	Heater element 2260 W / 230 V	HL70S(A)	SPZCU-823	
1	Heater element 3000 W / 230 V	HL90S(A)	SPZCU-830	
1	Heater element 3600 W / 230 V	HL110S(A)	SPZCU-836	
2	Evaporator heating element, assembled 2000 W / 230 V		SPZH-104	
3	Water tank		SPZCU-115	
4	Solenoid valve	HL70SA, HL90SA, HL110SA	SPZSS-610	
5	Overheating limiter switch		SPZSK-764	
6	Thermostat 110°C		SPZSN-250	
7	Soapstone cup		SPZH-205	
8	Thermostat reset button		SPO010	

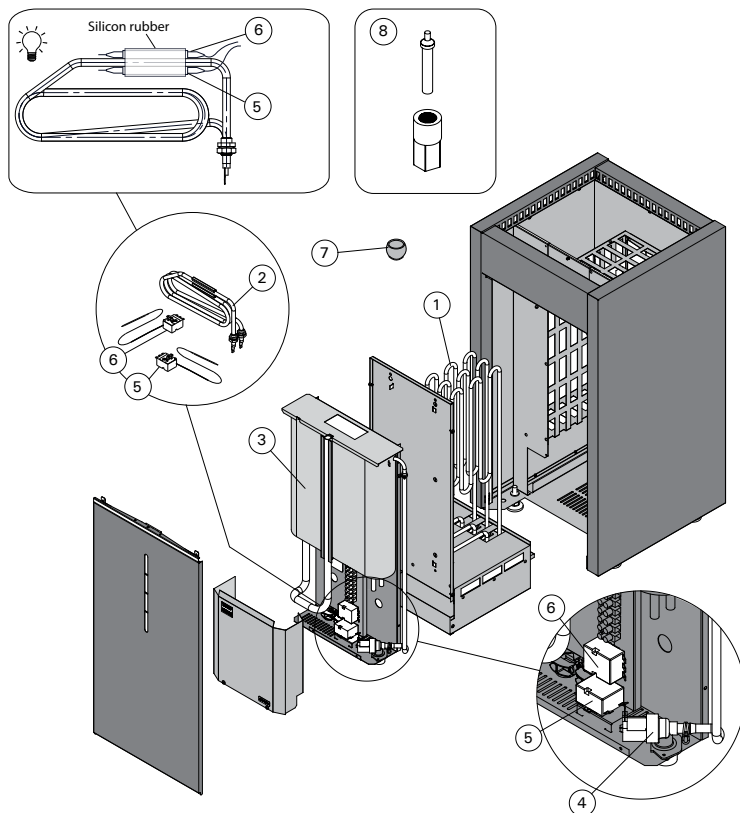



Virta Combi (USA/CANADA)

Itm.Nr. HL11U1SA, HLS11U1SA, HL11U3SA, HLS11U3SA, HL6U1SA, HLS6U1SA, HL8U1SA, HLS8U1SA, HL9U1SA, HLS9U1SA, HL11U1S, HLS11U1S, HL11U3S, HLS11U3S, HL6U1S, HLS6U1S, HL8U1S, HLS8U1S, HL9U1S, HLS9U1S

No.	Name	Type	Item code	pcs
1	Heating element 2000 W / 240 V	HL(S)6U1S(A)	SPY10-0021	3
1	Heating element 2250 W / 240 V	HL(S)7U1S(A)	SPY10-0010	3
1	Heating element 2650 W / 240 V	HL(S)8U1S(A)	SPY10-0020	3
1	Heating element 3000 W / 240 V	HL(S)9U1S(A)	SPY10-0009 / SPY10-0009SP	3
1	Heating element 3500 W / 240 V	HL(S)11U1S(A)	SPY10-0007	3
1	Heating element 3500 W / 208 V	HL(S)11U3S(A)	SPY10-0006	3
2	Evaporator heating element, assembled 2100 W / 240 V		SPZH-104	1
2	Evaporator heating element, assembled 2100 W / 208 V		SPY10-0012	1
3	Water reservoir, assembled		SPZCU-115	1
4	Solenoid valve		SPZSS-610	1
5	Overheating protector 140oC		SPZSK-765	1
6	Thermostat 110oC		SPZSN-250	1
7	Soapstone cup		SPZH-205	1
8	Silicon hose 7/10		SPZH-170	1
9	Silicon hose 12/16		SPZH-175	1
10	Steam control		SPZCU-614	1
11	Temperature sensor		SP248	1

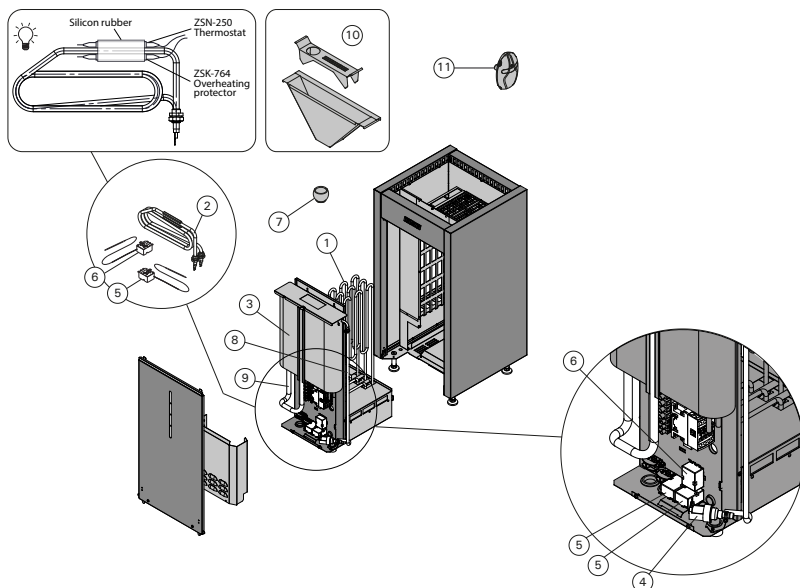

**Virta Pro****HL135 13.5 kW / HL160 15.8 kW / HL220 21.6 kW****Itm.Nr. HL135400, HL135400X, HL160400, HLS160400, HL160400X, HL220400, HLS220400, HL220400X**

No.	Name	Type	Item code	pcs
1	Heater element 2260 W / 230 V	HL135	SPZCU-823	6
1	Heater element 2260 W / 230 V	HL160	SPZCU-823	3
	3000 W / 230 V		SPZCU-830	3
1	Heater element 3600 W / 230 V	HL220	SPZCU-836	6
2	Thermostat reset button		SPO010	

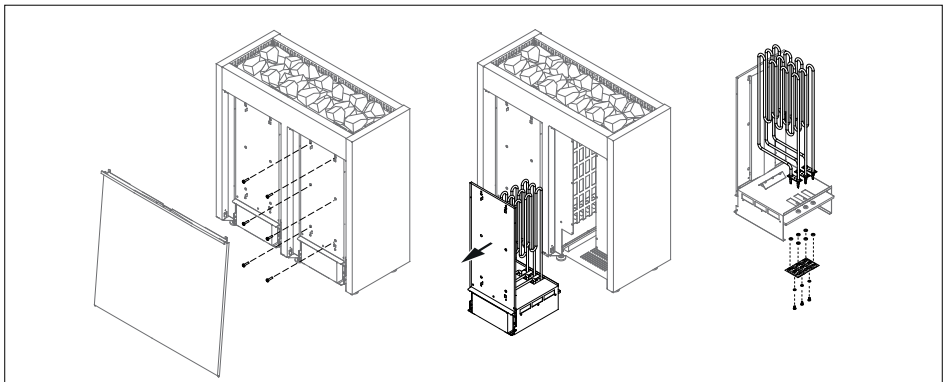
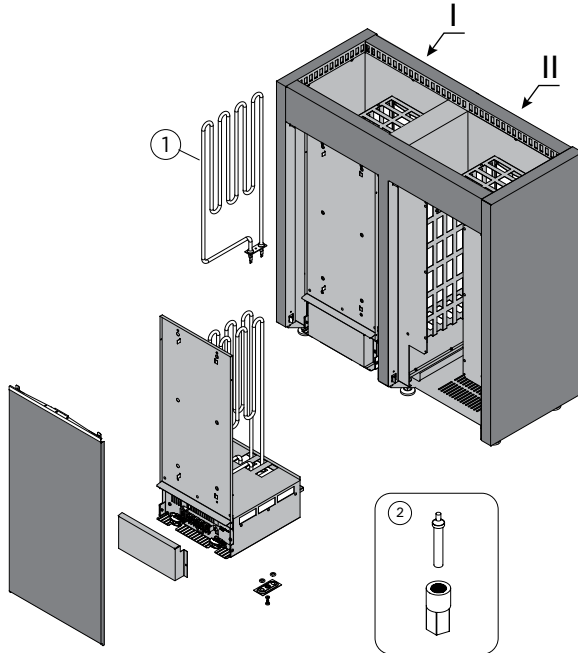



Virta Pro (USA/CANADA)

HL16U1 16 kW 240 V / HL20U3 20 kW 208V

Itm.Nr. HL16U1, HL20U3

No.	Name	Type	Item code	pcs
1	Heater element 2650 W / 240 V	HL16U1	SPY10-0020	6
1	Heater element 3500 W / 208 V	HL20U3	SPY10-0006	6
2	Overheat protector		SPZSK-765	1
3	Temperature sensor		SP248	1

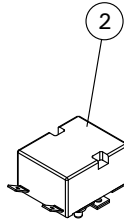
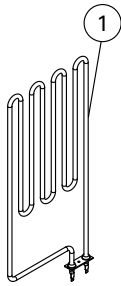



Virta Pro Combi

HL135SA 13.5 kW / HL160SA 15.8 kW / HL220SA 21.6 kW

Itm.Nr. HL135400SA, HL160400SA, HL220400SA, HL220400SAX

No.	Name	Type	Item code	pcs I	pcs II
1	Heater element 2260 W / 230 V	HL135SA	SPZCU-823	3	3
	Heater element 2260 W / 230 V	HL160SA	SPZCU-823	3	-
	Heater element 3000 W / 230 V	HL160SA	SPZCU-830	-	3
	Heater element 3600 W / 230 V	HL220SA	SPZCU-836	3	3
2	Heating element 2000 W / 230 V		SPZH-104		
3	Water reservoir, assembled		SPZCU-115		
4	Solenoid valve 230 VAC	HL135SA	SPZSS-610		
		HL160SA			
		HL220SA			
5	Overheating limiter switch, Combi heaters		SPZSK-764		
6	Thermostat 110°C		SPZSN-250		
7	Soapstone cup Ø 46/36		SPZH-205		
8	Steam control		SPZCU-614		

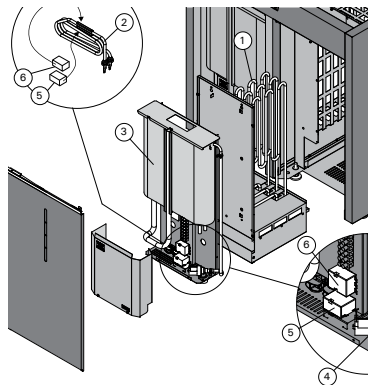

Replacing the Heating Elements

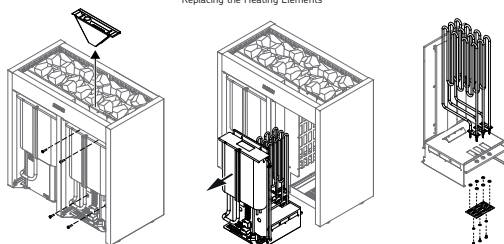



Virta (USA/CANADA)

HL60E 6.0 kW / HL70E / HL80E 8.0 kW / HL90E 9.0 kW / HL110E 11 kW

Itm.Nr. HL6U1, HL7U1, HL8U1, HL9U1, HL11U1, HL11U3, HLS6U1, HLS7U1, HLS8U1, HLS9U1, HLS11U1, HLS11U3

No.	Name	Type	Item code	pcs
1	Heating element 2000 W / 240 V	HL(S)6U1	SPY10-0021	3
1	Heating element 2250 W / 240 V	HL(S)7U1	SPY10-0010	3
1	Heating element 2650 W / 240 V	HL(S)8U1	SPY10-0020	3
1	Heating element 3000 W / 240 V	HL(S)9U1	SPY-0009	3
1	Heating element 3500 W / 240 V	HL(S)11U1	SPY10-0007	3
1	Heating element 3500 W / 208 V	HL(S)11U3	SPY-0006	3
2	Overheat protector		SPZSK-765	1
3	Temperature sensor		SP248	1

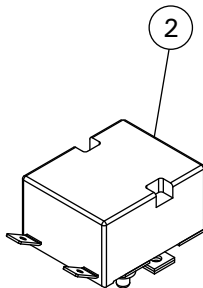
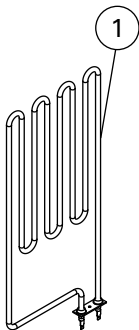



Virta

HL70 6.8 kW / HL90 9.0 kW / HL110 10.8 kW

Itm.Nr. HL700400, HL900400, HL110400

No.	Name	Type	Item code	pcs
1	Heating element 2260W 230V	HL70	SPZCU-823	
1	Heating element 3000W 230V	HL90	SPZCU-830	
1	Heating element 3600W 230V	HL110	SPZCU-836	

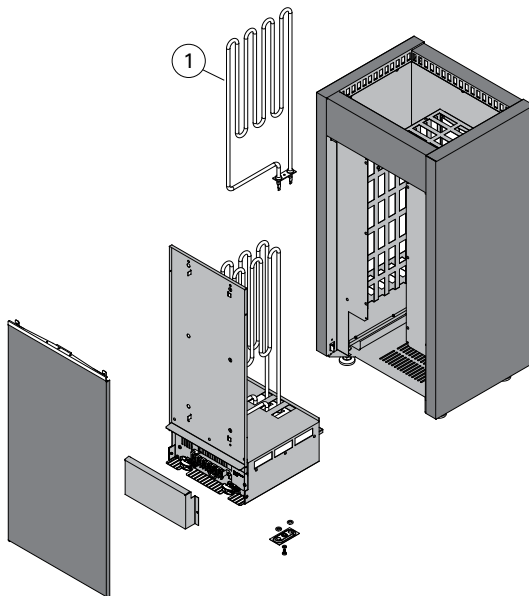

Replacing the heating elements

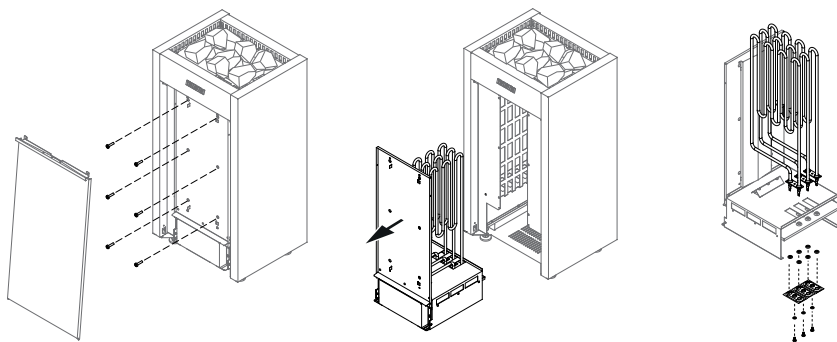



Virta Wall Combi

HLW60S 6.0 kW / HLW90S 9.0 kW

Itm.Nr. HLW60SM, HLW90SM

No.	Name	Type	Item code	pcs
1	Heater element 2000 W / 230V	HLW60S	SPSEN-007	3
2	Heater element 3000 W / 230V	HLW90S	SPSEN-009	3
3	Heating element 2000W / 230V		SPZH-104	1
4	Water tank Virta		SPZCU-115	1
5	Drain valve		SPZG-575	1
6	Overheating limiter switch fail-safe combi		SPZSK-764	1
7	Thermostat 110°C		SPZSN-250	1

3



5



6



7

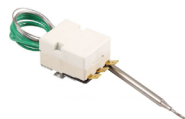

Virta Wall

HLW45E 4.5 kW / HLW60E 6.0 kW / HLW75E 7.5 kW / HLW90E 9.0 kW

Itm.Nr. HLWE454M, HLWE604M, HLWE754M, HLWE904M

No.	Name	Type	Item code	pcs
1	Heater element 1500 W	HLW45E	SPSEN-006	3
2	Heater element 2000 W	HLW60E	SPSEN-007	3
3	Heater element 2500 W	HLW75E	SPSEN-008	3
4	Heater element 3000 W	HLW90E	SPSEN-009	3



WOOD BURNING HEATERS

Cilindro 16

Itm.Nr. WKPC16S

Cilindro 20

Itm.Nr. WKPC20S

Pro 20 / Pro 20 RS / Pro 20 LS / Pro 20 ES / Pro 26 / Pro 36 / Linear 22 / Linear 28 (Versions 2024 or later)

Itm.Nr. WKPR20M, WKPR20RSM, WKPR20LSM, WKPR20ESM, WKPR26M, WKPR36M, WKLI20M, WKLI26M

Pro 20 / Pro 20 RS / Pro 20 LS / Pro 20 ES / Pro 26 / Pro 36 (Versions before 2024)

Itm.Nr. WKP200, WKP200RS, WKP200LS, WKP200ES, WKP260, WKP360

Cilindro 16

Itm.Nr. WKPC16S

No.	Name	Item code	pcs
1	Cap for smoke hole (Ø 115 mm)	SPZKIP-140	
2	Cap for smoke hole (Ø 50 mm)	SPZKIP-170	
3	Handle and screws, chrome	SPZKIP-670	
4	Door with glass (23 x 21,5 x 2,8 cm)	SP048	
5	Glass 184x210x4 mm, transparent	SPZTS-36	
6	Combustion air deflectors	SP524	
7	Connection pipe 200 mm	SPZKIP-130	
8	Ashpan	SP682	
9	Cast-iron grating 135x290mm	SPZKIP-10	

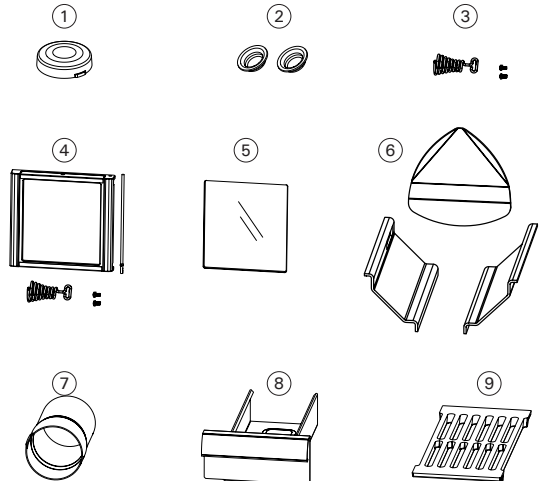
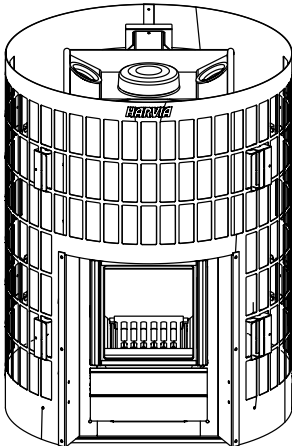

Cilindro 20

Itm.Nr. WKPC20S

No.	Name	Item code	pcs
1	Blocking plug	SPZROB-190	
2	Cap for smoke hole (Ø 75 mm)	SPZROB-430	(pack of 2)
3	Handle and screws, chrome	SPZKIP-670	
4	Door with glass, hinge pin and handle (23 x 21,5 x 2,8 cm)	SP048	
5	Combustion air deflectors	SP526	
6	Connection pipe 200 mm	SPZKIP-130	
7	Ashpan	SP682	
8	Cast-iron grating 135x290mm	SPZKIP-10	
9	Flue pipe connector	SPZROB-200	
10	Flue gas heat regulator	SPO009	(pack of 2)
11	Adjustable legs	SPZKIP-918	

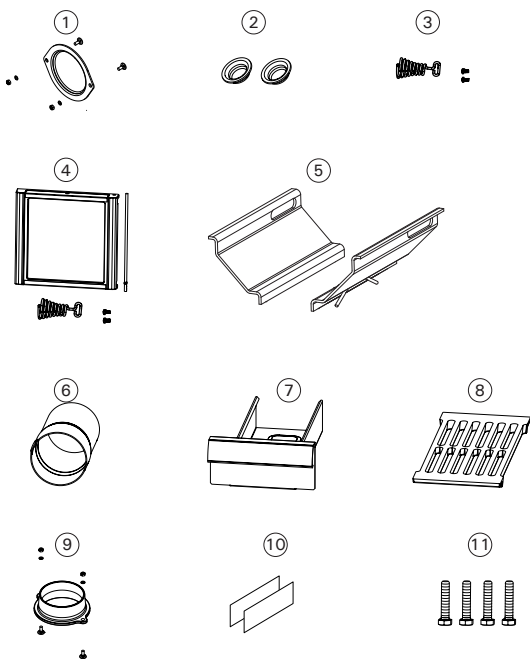
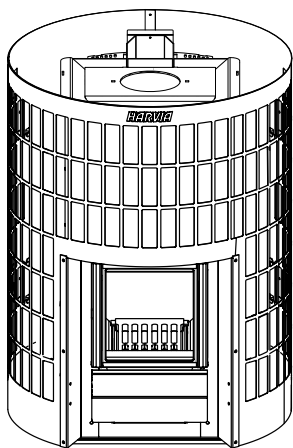

Note! Versions 2024 or later

Pro 20 / Pro 20 RS / Pro 20 LS / Pro 20 ES / Pro 26 / Pro 36 / Linear 22 / Linear 28 (Versions 2024 or later)

Itm.Nr. WKPR20M, WKPR20RSM, WKPR20LSM, WKPR20ESM, WKPR26M, WKPR36M, WKLI20M, WKLI26M

No.	Name	Type	Item code	pcs
1	Ashpan	Pro 20 ES	SP681	
2	Ashpan	Pro 20/RS/LS, Pro 26, Pro 36, Linear 22, Linear 28	SP682	
3	Flue pipe connector		SPZROB-200	
4	Connection pipe		SPZKIP-130	
5	Blocking plug		SPZROB-190	
6	Soot opening stopper		SPZKIP-170	
7	Stove door with glass		SPO48	
8	Glass		SPZTS-36	
9	Cast-iron grating		SPZKIP-10	
10	Water tap	Pro 20 RS/LS/ES	SPZVS-100	
11	Water container lid	Pro 20 RS/LS	SPZRST-619	
12	Water container	Pro 20 RS/LS	SP520	
13	Water container	Pro 20 ES	SP035	

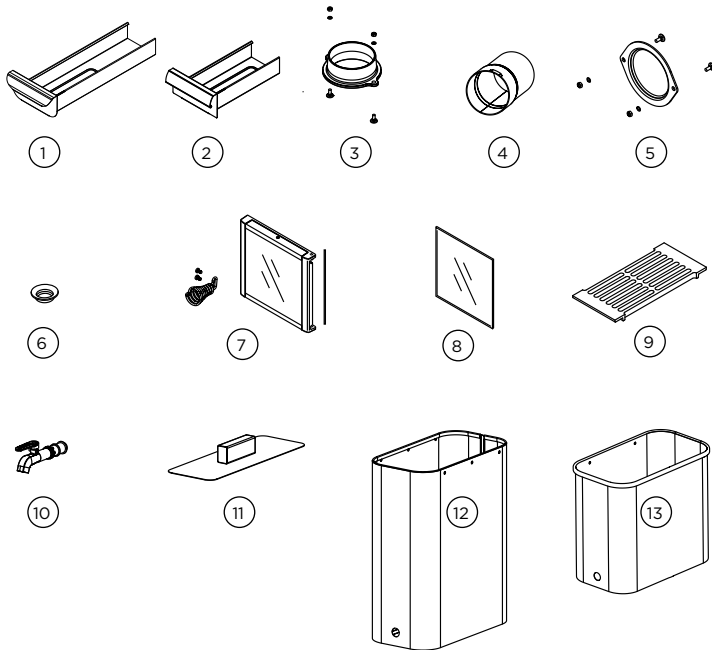

Note! Versions before 2024

Pro 20 / Pro 20 RS / Pro 20 LS / Pro 20 ES / Pro 26 / Pro 36 (Versions before 2024)

Itm.Nr. WKP200, WKP200RS, WKP200LS, WKP200ES, WKP260, WKP360

No.	Name	Item code	pcs
1	Ash box	Pro 20 ES	SP681
2	Ash box	Pro 20/ 20 RS/ 20 LS / 26 / 36	SP682
3	Connection pipe		SPZKIP-130
4	Cap for smoke hole (Ø115 mm)		SPZKIP-140
5	Stove door with glass		SP048
6	Glass		SPZTS-36
7	Cast-iron grating		SPZKIP-10
8	Water tap	Pro 20 RS/LS/ES	SPZVS-100
9	Water container lid	Pro 20 RS/LS	SPZROST-619
10	Water container	Pro 20 RS/LS	SP520
11	Water container	Pro 20 ES	SP035

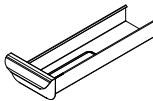

1

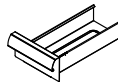

2



3



4

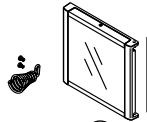

5



6

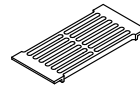

7



8

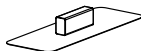

9

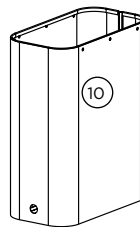

10

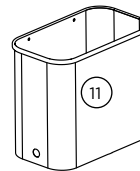

11



STEAM GENERATORS



HGD

HGD45XW 4.5kW WiFi / HGD60XW 6.0kW WiFi / HGD90XW 9.0kW WiFi / HGD110XW 11kW WiFi / HGD150XW 15kW WiFi

Itm.Nr. HGD45XW, HGD60XW, HGD90XW, HGD110XW, HGD150XW



HGP

HGP220XW 21.6 kW WiFi / HGP200XW 30 kW WiFi

Itm.Nr. HGP220XW, HGP300XW



HGX

HGX2 2.2 kW / HGX45 4.5 kW / HGX60 5.7 kW / HGX90 9.0 kW / HGX11 10.8 kW / HGX15 15.0 kW

Itm.Nr. HGX2, HGX45, HGX60, HGX90, HGX11, HGX15



HGX XW WiFi

HGX20XW 2.2 kW WiFi / HGX45XW 4.5kW WiFi / HGX60XW 5.7kW WiFi / HGX90XW 9.0 kW WiFi / HGX110XW 10.8 kW WiFi / HGX150XW 15 kW WiFi

Itm.Nr. HGX20XW, HGX45XW, HGX60XW, HGX90XW, HGX110XW, HGX150XW



HGD

HGD45XW 4.5kW WiFi / HGD60XW 6.0kW WiFi / HGD90XW 9.0kW WiFi / HGD110XW 11kW WiFi / HGD150XW 15kW WiFi

Itm.Nr. HGD45XW, HGD60XW, HGD90XW, HGD110XW, HGD150XW

No.	Name	Model	Item code	pcs.
1	Heating element 1500 W/230 V	HGD45XW	SPZG-330T	3
	Heating element 1900 W/230 V	HGD60XW	SPZG-340T	3
	Heating element 3000 W/230 V	HGD90XW	SPZG-350T	3
	Heating element 3600 W/230 V	HGD110XW	SPZG-360T	3
	Heating element 5000 W/230 V	HGD150XW	SPZG-365T	3
2	Sediment cup		SPZSTM-170	1
3	Manual discharge valve		SPZG-575	1
4	Overpressure valve		SPZG-580	1
5	Water level sensor		SPZSG-092	1
6	Nut		SPZSG-014	1
7	Solenoid valve		SPZG-379	1
8	Circuit board		SP645	1
9	Contactors		SPZSK-778	2
10	Main switch		SPZSK-684	1
11	Control panel		SP700	1

Optional parts and devices

12	Automatic discharge valve	ZG-700
13	Data cable 1.5 m	SP312
	Data cable 10 m	SP315
	Data cable 20 m	SP319
14	Fragrance pump	ZG-900
15	Connection part for fragrance pump	SPZSTM-195

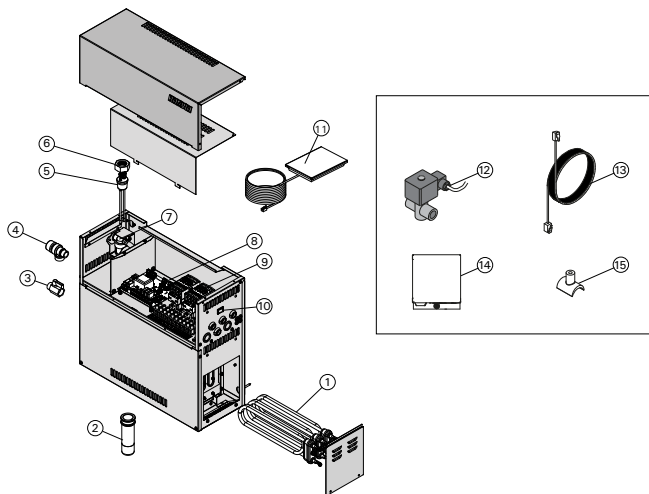



HGP

HGP220XW 21.6 kW WiFi / HGP200XW 30 kW WiFi

Itm.Nr. HGP220XW, HGP300XW

No.	Name	Model	Item code	pcs.
1	Heating element 3600 W / 230 V	HGP220XW	SPZSTM-260	6
	Heating element 5000 W / 230 V	HGP300XW	SPZSTM-261	6
2	Water level sensor assembly		SP620	1
3	Sediment cup		SPZSTM-170	1
4	Main switch		SPZSK-684	1
5	Circuit board, steam		SP645	1
6	Overheat protector		SPZG-550	1
7	Control panel Xenio WiFi steam		SP700	1
8	Gasket rubber D10, black		SPZSTM-150	1
9	Water supply hose HGP silicone, transparent		SPZSTM-227	1
10	Solenoid valve		SPZG-370	1
11	Plug rubber, black		SPZSTM-156	1
12	Automatic discharge valve		ZG-700	1
13	Gasket rubber HGP heating element set, black		SPZSTM-255	1
14	Contactors		ZSL-940	4
15	Hose pump, blue		SPZVR-779	1
16	Pipe adapter (1/2" - 3/4")		SPZSTM-225	1
Optional parts and devices				
17	Data cable 10m		WX315	1
	Data cable 20m		WX319	1

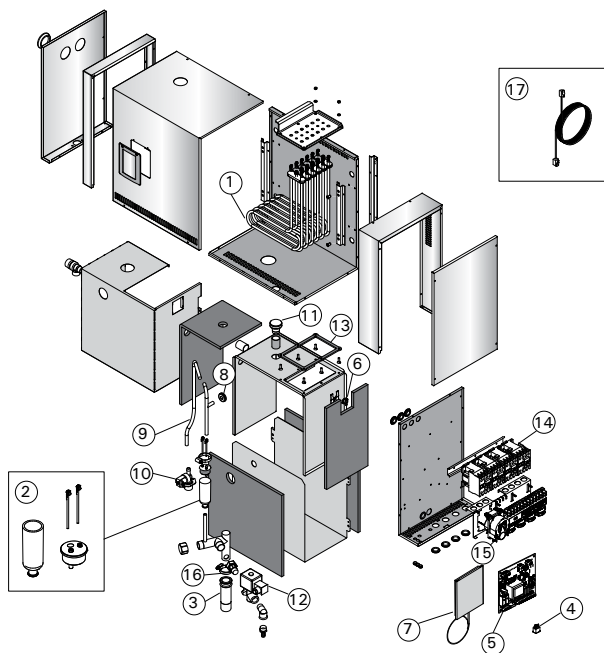



HGX

HGX2 2.2 kW / HGX45 4.5 kW / HGX60 5.7 kW / HGX90 9.0 kW / HGX11 10.8 kW / HGX15 15.0 kW

Itm.Nr. HGX2, HGX45, HGX60, HGX90, HGX11, HGX15

No.	Name	Model	Item code	pcs.
1	Heating element 2200 W/230 V	HGX2	SPZG-322	1
	Heating element 1500 W/230 V	HGX45	SPZG-330T	3
	Heating element 1900 W/230 V	HGX60	SPZG-340T	3
	Heating element 3000 W/230 V	HGX90	SPZG-350T	3
	Heating element 3600 W/230 V	HGX11	SPZG-360T	3
	Heating element 5000 W/230 V	HGX15	SPZG-365T	3
2	Drain valve hot water		SPZG-575	1
3	Pipe adapter 18 mm-G½"		SPZSTM-050	1
4	Measuring cup set (includes water level sensor, top and tube)		SP620	1
5	Water outlet pipe assembly, copper		SPZSTM-071	1
6	Service hatch cover plastic, transparent		SPZSTM-160	1
7	Sediment cup silicone, transparent		SPZSTM-170	1
8	Power switch and cover, white		SPZSK-684	1
9	Circuit board steam (gen.2018) power unit		SP645	1
10	Temperature sensor, steam		SPZG-660	1
11	Water tank, Stainless Steel	HGX2	SPZSTM-012	1
	Water tank, Stainless Steel	HGX45-HGX15	SPZSTM-010	1
12	Overheat protector		SPZG-550	1
13	Control panel		SP602	1
14	Gasket rubber D18, black		SPZSTM-140	4
15	Overpressure valve 0,5 BAR		SPZG-580	1
16	Rubber gasket D10, black		SPZSTM-150	1
17	Water supply hose		SPZSTM-047	1
18	Water supply pipe assembly, copper		SPZSTM-070	1
19	Outlet pipe D18 steam, copper		SPZSTM-040	1
20	Solenoid valve 230VAC, white		SPZSS-610	1
21	Plug rubber, black		SPZSTM-156	1
22	Steam nozzle		ZG-500	1
23	Contactora 4 blocks 30A 100-240VACDC 50/60 Hz		SPZSK-778	2
Optional parts and devices				
24	Automatic discharge valve		ZG-700	1
25	Fragrance pump		ZG-900	1
26	Connection part for fragrance pump		SPZSTM-195	1

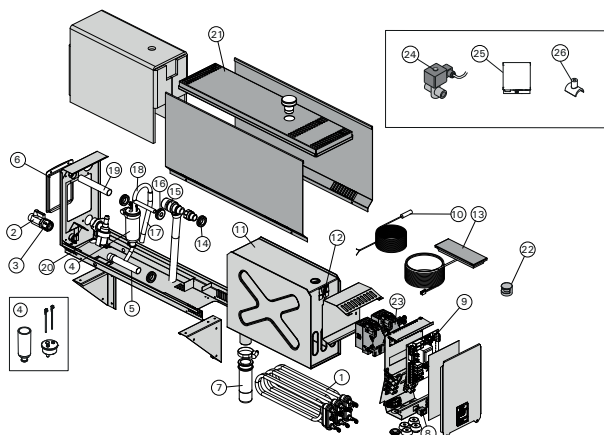



HGX XW WiFi

HGX20XW 2.2 kW WiFi / HGX45XW 4.5kW WiFi / HGX60XW 5.7kW WiFi / HGX90XW 9.0 kW WiFi / HGX110XW 10.8 kW WiFi / HGX150XW 15 kW WiFi

Itm.Nr. HGX20XW, HGX45XW, HGX60XW, HGX90XW, HGX110XW, HGX150XW

No.	Name	Model	Item code	pcs.
1	Heating element 2200 W/230 V	HGX2	SPZG-322	1
	Heating element 1500 W/230 V	HGX45	SPZG-330T	3
	Heating element 1900 W/230 V	HGX60	SPZG-340T	3
	Heating element 3000 W/230 V	HGX90	SPZG-350T	3
	Heating element 3600 W/230 V	HGX11	SPZG-360T	3
	Heating element 5000 W/230 V	HGX15	SPZG-365T	3
2	Drain valve hot water		SPZG-575	1
3	Pipe adapter 18 mm-G½"		SPZSTM-050	1
4	Measuring cup set (includes water level sensor, top and tube)		SP620	1
5	Water outlet pipe assembly, copper		SPZSTM-071	1
6	Service hatch cover plastic, transparent		SPZSTM-160	1
7	Sediment cup silicone, transparent		SPZSTM-170	1
8	Power switch and cover, white		SPZSK-684	1
9	Circuit board steam (gen.2018) power unit		SP645	1
10	Temperature sensor, steam		SPZG-660	1
11	Water tank, Stainless Steel	HGX2	SPZSTM-012	1
	Water tank, Stainless Steel	HGX45-HGX15	SPZSTM-010	1
12	Overheat protector		SPZG-550	1
13	Control panel		SP700	1
14	Gasket rubber D18, black		SPZSTM-140	4
15	Overpressure valve 0,5 BAR		SPZG-580	1
16	Rubber gasket D10, black		SPZSTM-150	1
17	Water supply hose		SPZSTM-047	1
18	Water supply pipe assembly, copper		SPZSTM-070	1
19	Outlet pipe D18 steam, copper		SPZSTM-040	1
20	Solenoid valve 230VAC, white		SPZSS-610	1
21	Plug rubber, black		SPZSTM-156	1
22	Steam nozzle		ZG-500	1
23	Contactora 4 blocks 30A 100-240VACDC 50/60 Hz		SPZSK-778	2
Optional parts and devices				
24	Automatic discharge valve		ZG-700	1
25	Fragrance pump		ZG-900	1
26	Connection part for fragrance pump		SPZSTM-195	1
27	Data cable 10 m		SP315	1
	Data cable 20 m		SP319	1

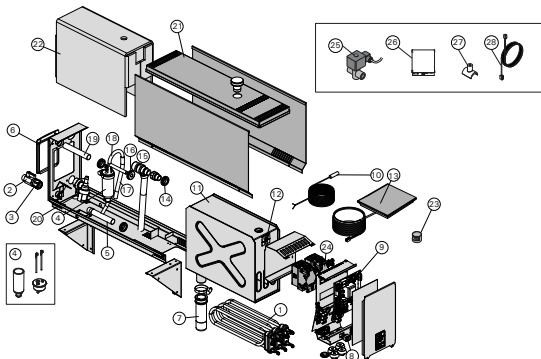

CONTROL UNITS



C80, C90, C150
Itm.Nr. C080230, C090400, C150400



C170VKK
Itm.Nr. C170400VKK



C400VKK
Itm.Nr. C400400VKK



FENIX 110
Itm.Nr. FX1104XC



FENIX 110 Combi
Itm.Nr. FX1104CX



FENIX 170
Itm.Nr. FX1704XC



FENIX FX30 280V/240V, FX45 208V/240V
Itm.Nr. FX30-U1-U3-XC, FX45-U1-U3-XC



FENIX Combi FX30C 12,7 kW 240V / 10,8kW 208V
Itm.Nr. FX30C-U1-XC, FX30C-U3-XC



Xenio Combi CX110CXW WiFi
Itm.Nr. CX1104CXW



Xenio CX170
Itm.Nr. CX170400



Xenio CX170WIFI
Itm.Nr. CX1704XW



Xenio CX30/CX45 (USA/CANADA)
280V / 240V
Itm.Nr. CX30-U1-U3, CX30-U1-U3-XW, CX45-U1-U3



Xenio Combi CX30C (USA/CANADA)
12,7 kW 240V / 10,8kW 208V
Itm.Nr. CX30C-U1, CX30C-U1-XW, CX30C-U3, CX30C-U3-XW



Xenio CX45J (JAPAN)
200-208 VAC
Itm.Nr. CX45J



Xenio CX180-45, CX180-45XW (max.9-29 kW)
Itm.Nr. CX180-45, CX180-45XW



LTY180-45
Itm.Nr. LTY180-45



C80, C90, C150

Itm.Nr. C080230, C090400, C150400

no.	Name	Model	Item code
1	Display card	C80, C90, C150	SP200
2	Electric power card	C80	SP218
3	Electric power card	C90	SP211
4	Electric power card	C150	SP212

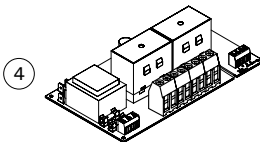
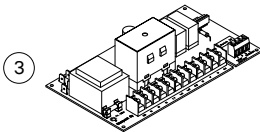
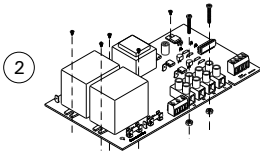
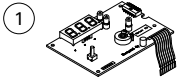

(A) Main fuse
 (B) Fuse for light
 (C) Fuse for control of heating
 Press here to detach

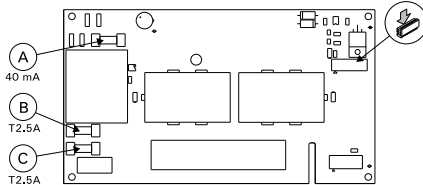
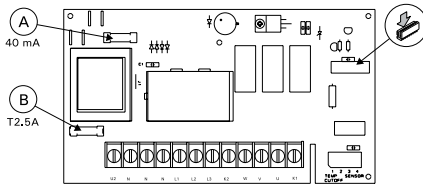
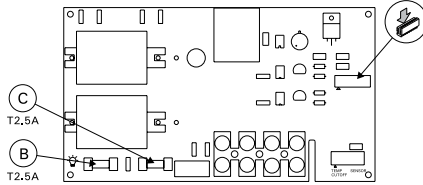



C170VKK

Itm.Nr. C170400VKK

No	Name	Item code
1	Touch screen	SP680
2	Temperature sensor (must be installed)	SP232
3	Temperature sensor (optional)	SP325
4	Data cable	SP679
5	Circuit board (SERNO: 2010000000 →)	SP351

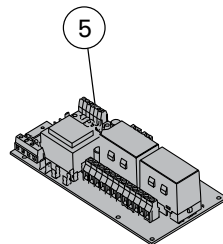
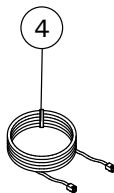
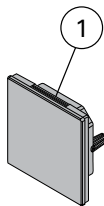



C400VKK

Itm.Nr. C400400VKK

No	Name	Item code
1	Touch screen	SP680
2	Temperature sensor (must be installed)	SP232
3	Temperature sensor (optional)	SP325
4	Data cable	SP679
5	Circuit board	SP358

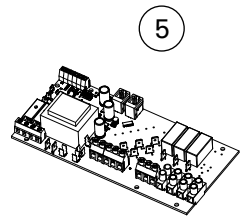
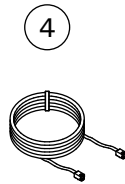
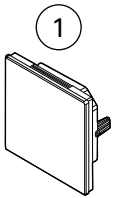



FENIX 110

Itm.Nr. FX1104XC

No	Name	Item code
1	Fenix FX110 Control panel core	SP392
2	Fenix FX110 backplate + mounting kit	SP393
3	Temperature Sensor black (135°C)	SP247M
4	Data cable (5m)	SP311
4	Data cable 10 m (accessory)	SP315
4	Data cable 20 m (accessory)	SP319
5	Circuit board for FX1104XC and CX1104XWIP	SP394

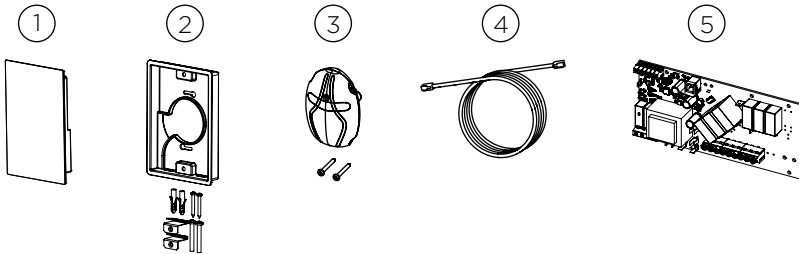

FENIX 110 Combi

Itm.Nr. FX1104CXC

No	Name	Item code
1	Fenix FX110 Control panel core	SP392
2	Fenix FX110 backplate + mounting kit	SP393
3	Temperature Sensor black (135°C)	SP247M
4	Temperature Sensor / humidity black	SP325M
5	Data cable (5m)	SP311
5	Data cable 10 m (accessory)	SP315
5	Data cable 20 m (accessory)	SP319
6	Circuit board for FX1104CXC and CX1104CXW	SP356

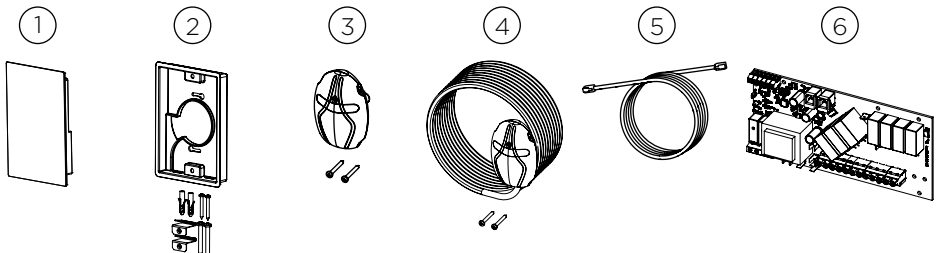



FENIX 170

Itm.Nr. FX1704XC

No	Name	Item code
1	Fenix FX110 Control panel core	SP392
2	Fenix FX110 backplate + mounting kit	SP393
3	Temperature Sensor black (135°C)	SP247M
4	Temperature Sensor (optional)	SP325M
5	Data cable (5m)	SP311
5	Data cable 10 m (accessory)	SP315
5	Data cable 20 m (accessory)	SP319
6	Circuit board for FX1104XC and CX1104XWIP	SP351

1

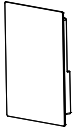

2

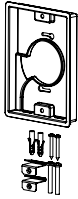

3



4

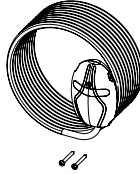

5

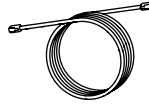

6

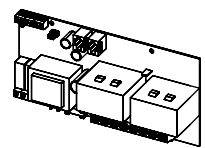

**FENIX FX30 280V/240V, FX45 208V/240V****Itm.Nr. FX30-U1-U3-XC, FX45-U1-U3-XC**

No	Name	Item code
1	Fenix FX110 Control panel core	SP392
2	Fenix FX110 backplate + mounting kit	SP393
3	Temperature Sensor black (135°C)	SP247M
4	Data cable 5 m	SP311
4	Data cable 10 m (accessory)	SP315
4	Data cable 20 m (accessory)	SP319
5	Circuit board	SP361
6	Contactor 30 A (FX30-U1-U3-XW)	SPZSK-778
7	Contactor 45 A (FX45-U1-U3-XW)	SPZSL-940

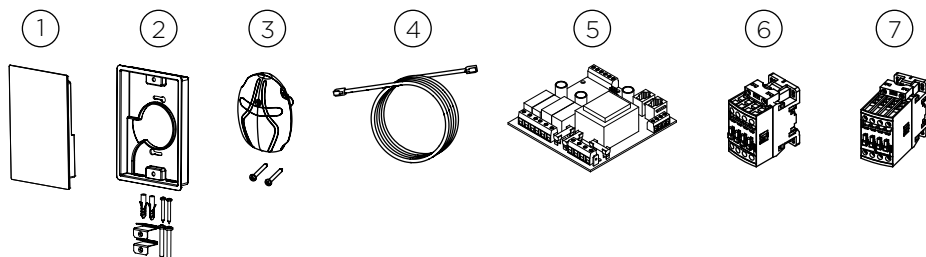
**FENIX Combi FX30C 12,7 kW 240V / 10,8kW 208V****Itm.Nr. FX30C-U1-XC, FX30C-U3-XC**

No	Name	Item code
1	Fenix FX110 Control panel core	SP392
2	Fenix FX110 backplate + mounting kit	SP393
3	Temperature Sensor black (135°C)	SP247M
4	Temperature Sensor /humidity black	SP325M
5	Data cable 5 m	SP311
5	Data cable 10 m (accessory)	SP315
5	Data cable 20 m (accessory)	SP319
6	Circuit board	SP357
7	Contactor 30 A	SPZSK-778

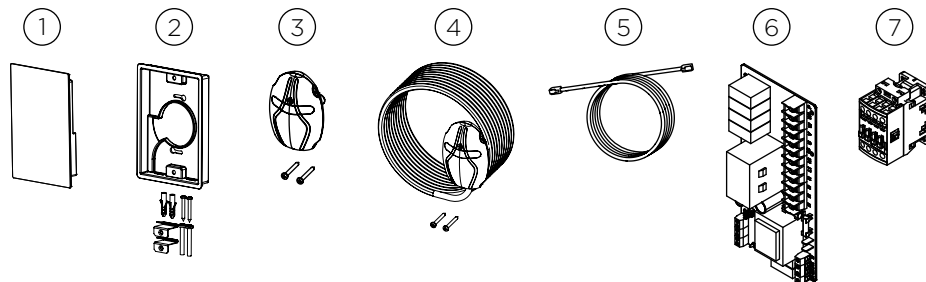



Xenio Combi CX110CXW WiFi

Itm.Nr. CX1104CXW

No	Name	Item code
1	Control panel Xenio Wifi	SP694
2	Temperature sensor 150°C	SP232
3	Temperature sensor	SP325
4	Data cable 5 m RJ16	SP311
5	Power card	SP356

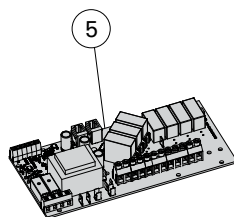
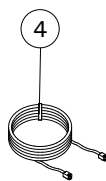
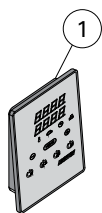



Xenio CX170

Itm.Nr. CX170400

No	Name	Item code
1	Xenio Control panel	SP380
2	Temperature sensor (150°C)	SP232
3	Temperature sensor (optional)	SP325
4	Data cable (5m)	SP311
5	Circuit board	SP351



Xenio CX170WIFI

Itm.Nr. CX1704XW

No	Name	Item code
1	Xenio Control panel	SP694
2	Temperature sensor (150°C)	SP232
3	Temperature sensor (optional)	SP325
4	Data cable (5m)	SP311
5	Circuit board	SP351

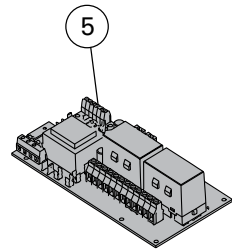
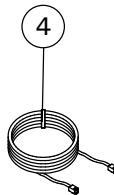

**Xenio CX30/CX45 (USA/CANADA)****280V / 240V****Itm.Nr. CX30-U1-U3, CX30-U1-U3-XW, CX45-U1-U3**

No	Name	Item code
1	Control panel Control panel Xenio WiFi	SP387 SP694
2	Data cable 5 m	SP311
3	Data cable extension 10 m (accessory)	SP315
4	Temperature sensor, 150°C	SP232
5	Circuit board	SP361
6a	Contactor 30 A (CX30-U1-U3, CX30-U1-U3-XW)	SPZSK-778
6b	Contactor 45 A (CX45-U1-U3, CX45-U1-U3-XW)	SPZSL-940
7	Data cable 20 m (accessory)	SP319

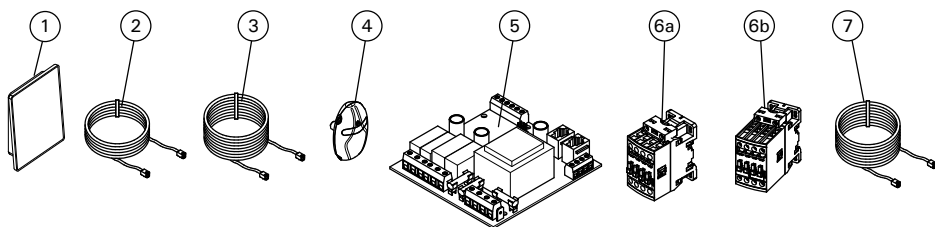
**Xenio Combi CX30C (USA/CANADA)****12,7 kW 240V / 10,8kW 208V****Itm.Nr. CX30C-U1, CX30C-U1-XW, CX30C-U3, CX30C-U3-XW**

No	Name	Item code
1	Control panel Control panel Xenio WiFi	SP387 SP694
2	Data cable 5 m	SP311
3	Temperature sensor	SP232
4	Humidity sensor	SP325
5	Circuit board	SP357
6	Contactor 30 A (CX30C-U1, CX30C-U1-XW, CX30C-U3, CX30C-U3-XW)	SPZSK-778

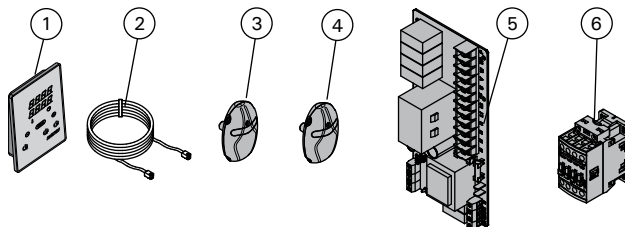



Xenio CX45J (JAPAN)

200-208 VAC

Itm.Nr. CX45J

No	Name	Item code
1	Control panel	SP387
2	Temperature sensor	SP232
3	Data cable 5 m	SP311
4	Data cable extension 10 m (optional)	SP313
5	Circuit board	SP361J

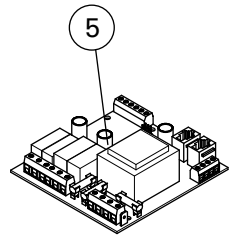
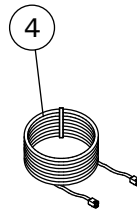
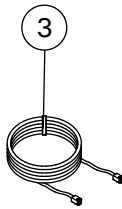



Xenio CX180-45, CX180-45XW (max.9-29 kW)

Itm.Nr. CX180-45, CX180-45XW

No	Name	Item code
1	Temperature sensor	SP232
2	Data cable 5m	SP311
3	Control panel (WiFi)	SP694
4	Control panel	SP387
5	Circuit board	SP361U
6	Contactors	SPZSL-940

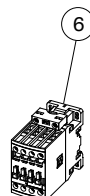
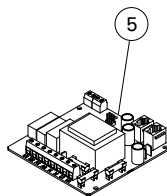
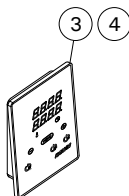
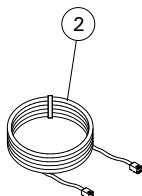

LTY180-45

Itm.Nr. LTY180-45

No	Name	Item code
1	Contactors	SPZSL-940

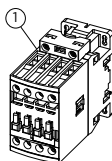

ACCESSORIES

Safety Switch (Control unit accessory)

Itm.Nr. SFE-220400, SFE-350400, SFE-500500, SFE-D350, SFE-D450, SFE-D530

Safety Switch (Control unit accessory)

Itm.Nr. SFE-220400, SFE-350400, SFE-500500, SFE-D350, SFE-D450, SFE-D530

No.	Name	Type	Item code	pcs
1	Micro switch		SPY08-0008	
2	Spring		SPY06-0023	

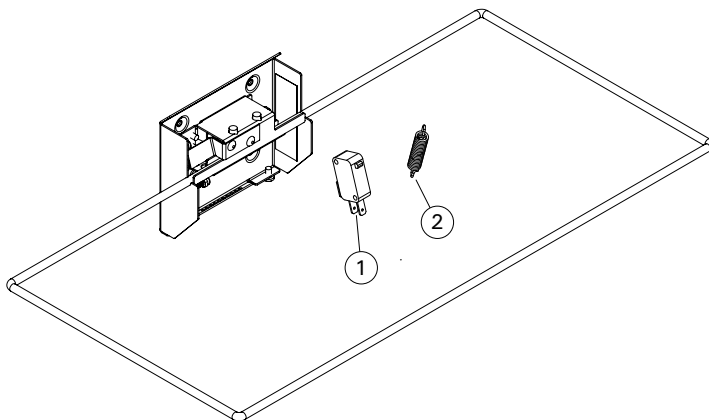

SAUNA CABINS



Domo Small
166x159x204 cm
Itn.Nr. Domo-S



Domo Medium
196x159x204 cm
Itn.Nr. Domo-M



Domo Large
196x189x204 cm
Itn.Nr. Domo-L



Kammi Barrel Large
220X220 cm
Itn.Nr. KAMMI-BAR-220



Kammi Cube
220X220 cm
Itn.Nr. KAMMI-CUBE-220



Solide Vision
203x203x265cm / 259x269x265cm
Itn.Nr. SLD-VIS



Soma
120x100x190 cm
Itn.Nr. SGV1210MT



Domo Small

166x159x204 cm

Itm.Nr. Domo-S

No.	Name	Dimensions (cm)	Item code	pcs
Walls				
1	Wall Right side, lower part Electric element	154,5x102x4		1
2	Wall Right side, upper part Electric element	154,5x108x4		1
3	Wall Back side, lower part Ventilation element	154,5x102x4		1
4	Wall Back side, upper part	154,5x108x4		1
5	Wall Left side, lower part Electric element	154,5x102x4		1
6	Wall Left side, upper part Electric element	154,5x108x4		1
7	Element above glass, inside	142,5x12,1x4		1
8	Element with groove for glass, left	202,5x6x4		1
9	Element with groove for glass, right	202,5x6x4		1
10	Mounting strip above door	59,7x1,8x0,8		1
11	Cover element front	202,5x11,5x4		2
12	Cover element front , upper side	142,5x10,6x4		1
Ceiling				
13	Ceiling panels	146,7x76,8x5,6		2
Glasses				
14	Glassdoor	190x59x0,8		1
15	Glass with drillings for hinges	193x58x0,8		1
16	Glass	193x27,5x0,8		1
Support elements				
17	Bench support strips	57x4x4		3
18	Bench support strips	97x4x4		2
19	Ceiling support strips	138,5x4x4		2
20	Ceiling support strips	154,5x4x4		1
21	Ceiling support strip with LED	154,5x4x4		1
22	Cover strips for outside	202,5x8x1,5		4
23	Cover strips for above	138,5x8x1,5		2
24	Cover strips for inside	145,5x8x1,5		1
Interior				
25	Bench	153,5x57x8		1
26	Bench	153,5x50x8		1
27	Bench	74x57x8		1
28	Bench support foot	57x94x6		1
29	Cable cover strip	200x4x3		1
30	Heaterguard element	39x73x5		1



No.	Name	Dimensions (cm)	Item code	pcs
31	Heaterguard element	30x43x5		2
Accessories				
32	Headrest type "Basic"	30x28x7		1
33	Door handle set		SAZ562	1
34	LED RGBW - pre-assembled in ceiling support strip18	154,5x2,1x1,7		1
35	LED Technik 40W		LED-230-SD-40	1
36	Sauna ventilation cover	52x14x1,5	AIR-VENT	1
37	Door magnet, sleeve plate chrom		SAZ800	1
38	Door hinges		SAZ3309S	2
39	U-Alu Profile	56.7		1
40	U-Alu Profile	26.2		1
41	Assembly material set			1
42	Assembly instruction			1





Domo Medium
196x159x204 cm
Itm.Nr. Domo-M

No.	Name	Dimensions (cm)	Item code	pcs
Walls				
1	Wall Right side, lower part Electric element	154,5x102x4		1
2	Wall Right side, upper part Electric element	154,5x108x4		1
3	Wall Back side, lower part Ventilation element	185x102x4		1
4	Wall Back side, upper part,	185x108x4		1
5	Wall Left side, lower part Electric element	154,5x102x4		1
6	Wall Left side, upper part Electric element	154,5x108x4		1
7	Element above glass, inside	173x12,1x4		1
8	Element with groove for glass, left	202,5x6x4		1
9	Element with groove for glass, right	202,5x6x4		1
10	Mounting strip above door	59,7x1,8x0,8		1
11	Cover element front	202,5x11,5x4		2
12	Cover element front , upper side	173x10,6x4		1
Ceiling				
13	Ceiling panels	146,7x92x5,6		2
Glasses				
14	Glassdoor	190x59x0,8		1
15	Glass with drillings for hinges	193x58x0,8		1
16	Glass	193x58x0,8		1
Support elements				
17	Bench support strips	57x4x4		3
18	Bench support strips	88,5x4x4		2
19	Ceiling support strips	138,5x4x4		2
20	Ceiling support strips	185x4x4		1
21	Ceiling support strip with LED	185x4x4		1
22	Cover strips for outside	202,5x8x1,5		4
23	Cover strips for above	138,5x8x1,5		2
24	Cover strips for inside	145,5x8x1,5		1
Interior				
25	Bench	184x57x8		1
26	Bench	184x50x8		1
27	Bench	82,5x57x8		1
28	Bench support foot	57x94x6		1
29	Cable cover strip	200x4x3		1
30	Heaterguard element	52x73x5		1



No.	Name	Dimensions (cm)	Item code	pcs
31	Heaterguard element	36x43x5		2
Accessories				
32	Headrest type "Basic"	30x28x7		1
33	Door handle set		SAZ562	1
34	LED RGBW - pre-assembled in ceiling support strip18	185x2,1x1,7		1
35	LED Technik 40W		LED-230-SD-40	1
36	Sauna ventilation cover		AIR-VENT	1
37	Door magnet, sleeve plate chrom		SAZ800	1
38	Door hinges		SAZ3309S	2
39	U-Alu Profile	56.7		1
40	U-Alu Profile	26.2		1
41	Assembly material set			1
42	Assembly instruction			1





Domo Large

196x189x204 cm

Itm.Nr. Domo-L

No.	Name	Dimensions (cm)	Item code	pcs
Walls				
	Wall Right side, lower part Electric element	185x102x4		1
	Wall Right side, upper part Electric element	185x108x4		1
	Wall Back side, lower part Ventilation element	185x102x4		1
	Wall Back side, upper part, Electric element	185x108x4		1
	Wall Left side, lower part Electric element	185x102x4		1
	Wall Left side, upper part Electric element	185x108x4		1
	Element above glass, inside	173x12,1x4		1
	Element with groove for glass,left	202,5x6x4		1
	Element with groove for glass,right	202,5x6x4		1
	Mounting strip above door	59,7x1,8x0,8		1
	Cover element front	202,5x11,5x4		2
	Cover element front , upper side	173x10,6x4		1
Ceiling				
	Ceiling panels	177,2x92x5,6		2
Glasses				
	Glassdoor	190x59x0,8		1
	Glass with drillings for hinges	193x58x0,8		1
	Glass	193x58x0,8		1
Support elements				
	Bench support strips	57x4x4		3
	Bench support strips	114x4x4		2
	Ceiling support strips	169x4x4		2
	Ceiling support strips	185x4x4		1
	Ceiling support strip with LED	185x4x4		1
	Cover strips for outside	202,5x8x1,5		4
	Cover strips for above	169x8x1,5		2
	Cover strips for inside	176x8x1,5		1
Interior				
	Bench	184x57x8		2
	Bench	113x57x8		1
	Bench support foot	57x94x6		1
	Cable cover strip	200x4x3		1
	Heaterguard element	52x73x5		1



No.	Name	Dimensions (cm)	Item code	pcs
	Heaterguard element	36x43x5		2
Accessories				
	Headrest type "Basic"	30x28x7		1
	Door handle set		SAZ562	1
	LED RGBW - pre-assembled in ceiling support strip18	185x2,1x1,7		1
	LED Technik 40W		LED-230-SD-40	1
	Sauna ventilation cover		AIR-VENT	1
	Door magnet, sleeve plate chrom		SAZ800	1
	Door hinges		SAZ3309S	2
	U-Alu Profile	56.7		1
	U-Alu Profile	26.2		1
	Assembly material set			1
	Assembly instruction			1





Kammi Barrel Large

220X220 cm

Itm.Nr. KAMMI-BAR-220

No.	Name	Dimensions (cm)	Item code	pcs
1	Sauna feet (impregnated)	1600x225x70		3
2	Beginner stave with hole for water drain	2200x115x40		1
3a	Staves	2200x115x40		67
3b	Staves with cable duct	2200x115x40		4
4	Staves filling set	2200x45x40		2
5	Staves filling set	2200x30x40		1
6	Staves filling set	2200x20x40		2
7a	Front wall	2095x817x65		1
7b	Front wall	585x332x65		1
7c	Front wall	2095x817x65		1
7d	Front wall	525x133x65		1
8a	Back wall	2031x747x65		1
8b	Back wall	2160x735x65		1
8c	Back wall	2031x747x65		1
9	Bench support strips	540x60x40		4
10	Roof element (weather bar)	2200x42x42		2
11	Floorgrid	980x595x40		2
12	LED support strip	800x25x25		1
13	Glass door with frame outside	1690x590x92		1
14	Door knob			1
15a	Door outside cover strip	1660x45x16		2
15b	Door outside cover strip	663x45x16		2
16	Roof element (weather bar)	663x33x19		1
17a	Door inside cover strip	1690x28x38		2
17b	Door inside cover strip	646x28x38		2
18	Benches	1990x600x90		2
19	Backrests	1930x260x40		2
20	Wooden rim roof	510x70x20		14
21	LED 76cm white dimable		LED-W-76-BS	1
22	Power supply 12V30W for LED 76cm		PS-12V30W	1
23	Stainless steel element 1 Holder metal band			6
24	Stainless steel element 2 Metal band			3
25	Stainless steel element 3 Nut			6
26	Stainless steel element 4 Washer			6
27	Stainless steel element 5 Threaded rod			3
28a	Ventilation cover outside	Ø180		2
28b	Ventilation cover	Ø180		1
29	Adjustable air inlet cover	Ø180		1



No.	Name	Dimensions (cm)	Item code	pcs
30	Bitumen shingles		SH-B-16-232	4
31	Metal angle	40x40x20		4
32	Nails and screws			
33	Plastic element for sauna foot	100x30x4		18
34	T-cork ø20			1
35	Heater guard element	620x115x25		1
36	Heater guard element	460x60x25		2
37	Heater guard element	315x60x25		2
38	Heater guard element	340x40x20		2
39	Bitumen sealant 300ml			1



**Kammi Cube****220X220 cm****Itm.Nr. KAMMI-CUBE-220**

No.	Name	Dimensions (cm)	Item code	pcs
1	Sauna feet (impregnated)	1500x155x70		3
2a	Beginner stave	2200x84x40		1
2b	Beginner stave with hole for water drain	2200x84x40		1
3	Staves	2200x115x40		78
4	Staves with cable duct	2200x115x40		2
5	Staves filling set	2200x93x40		2
6a	Stave filling	2200x20x40		2
6b	Stave filling	2200x30x40		2
7a	Front wall W1	2166x725x65		1
7b	Front wall W2	710x100x40		1
7c	Front wall W3	2166x725x65		1
7d	Front wall W4	710x80x40		1
8	Back wall W5	2160x1435x65		1
9	Halfround window	2160x725x40		1
10	Window cover strips/Door inside cover strip	2120x40x20		4
11	Floorgrid	980x595x40		2
12	LED support strip	800x25x25		1
13	Door frame + glass door	2080x750x60		1
14	Doorhandle Set 900mm	900x40x140		1
15	Door inside cover strip	650x40x20		2
16	Door mounting strips	2000x20x20		2
17	Roof element	2200x42x42		2
18	Benches	1990x520x90		2
19	Benches	1990x300x90		2
20	Backrests	1930x260x40		2
21	Bench support strips	480x60x40		4
22	Bench support strips	260x60x40		4
23	Bench support foot	430x60x40		2
24a	LED 76cm white dimable		LED-W-76-BS	1
24b	Power supply 12V30W for LED	76cm	PS-12V30W	1
25	Holder metal band			6
26	Metal band			3
27	Nut			6
28	Washer			6
29	Threaded rod			3
30	Ventilation cover outside	Ø180		2
31	Adjustable air inlet cover	Ø180		2
32	T-cork ø20			1



No.	Name	Dimensions (cm)	Item code	pcs
33	Plastic element for sauna foot	100x30x4		18
34	Bitumen Roof felt	225x100x2		5
35a	Wooden rim roof front side	1000x90x20		2
35b	Wooden rim roof front side	400x70x20		4
35c	Wooden rim roof front side	520x70x20		8
36a	Heater guard element	800x115x20		1
36b	Heater guard element	400x60x20		2
36c	Heater guard element	55x30x30		2
37	Bitumen shingles		SH-B-16-232	5
38	Bitumen sealant	300ml		2
39	Screws + nails			





Solide Vision

203x203x265cm / 259x269x265cm

Itm.Nr. SLD-VIS

No.	Name	Dimensions (cm)	Item code	pcs
Floor				
1	Floor frame (waterproof)	1905x100x40		2
2	Floor frame (waterproof)	1905x95x40		2
3	Floor frame (waterproof)	1905x90x40		2
4	Floor frame (waterproof)	1905x85x40		2
5	Floor boards	930x105x19		42
6	Cover strips	1910x25x20		1
7	Cover strips	1055x25x20		2
8	Cover strips	780x25x20		1
9	Cover strips	105x25x20		1
10	Cover strips	95x25x20		1
W1: Side wall with door				
11	Bottom timber impregnated	1910x146x40		1
12	Timber	1085x146x40		14
13	Crossing the door	1910x146x40		1
14	Timber upper triangle	1910x397x40		1
W2: Back wall				
15	Bottom timber impregnated	1990x146x40		1
16	Timber	1990x146x40		14
17	Timber (cutout for air outlet)	1990x131x40		1
18	Timber (cutouts for roof air supply)	1990x131x40		1
W3: Side wall				
19	Bottom timber impregnated	1910x146x40		1
20	Timber	1910x146x40		14
21	Timber (cutout for air inlet)	1910x146x40		1
22	Timber Upper triangle	1910x397x 40		1
W4: Front wall with window				
23	Bottom timber impregnated	1990x146x40		1
24	Bottom timber under the window	1990x146x40		1
25	Timber with slot - lower part	185x826x40		1
26	Timber with slot - upper part	185x826x40		1
27	Timber with drilling for screws	185x146x40		12
28	Upper timber above the window	1990x146x40		1
29	Upper timber	1990x146x40		3
30	Timber (cutouts for roof air supply)	1990x131x40		1
Corner covers				
31	Corner cover	1445x80x20		2
32	Corner cover	1165x80x20		2
33	Corner cover	1135x80x20		8



No.	Name	Dimensions (cm)	Item code	pcs
34	Corner cover 82°	1445x80x20		2
35	Corner cover 82°	1178x80x20		2
Roof inside				
36	Roof panel	1890x955x55		1
37	Roof panel	1890x955x55		1
38	Roof laths 82° - W2	1910x40x40		1
39	Roof laths - W4	1910x40x40		1
40	Roof laths 2x82° right - W1	1847x40 40		1
41	Roof laths 2x82° left - W3	1847x40x40		1
Roof outside				
42	Roof rafters - left	1425x130x40		4
43	Roof rafters - right	1425x130x40		4
44	Mounting plates for rafters	500x130x13		8
45	Roof tongue and groove boards	1617x95x19		27
46	Roof tongue and groove boards	1056x95x19		27
47	Fascia boards support laths 82° - W4	1275 x 130 x 40		2
48	Fascia boards support laths 82° - W2	1275 x 40 x 40		2
49	Roof fascia boards 82° - W1, W3	1338 x 150x 20		4
50	Roof fascia boards - W2, W4	1295 x 150 x 20		4
51	Wind boards for roof shingles	1360x50x20		6
Window				
52	Window frame including glass	1883x850x80		2
53	Window frame cover outside	1883x70x20		1
54	Window frame cover inside	1883x70x20		4
55	Window frame cover inside	745x70x20		4
Door				
56	Door	1900x820x50		1
57	Door frame cover profile - outside	1955x55x20		1
58	Door frame cover profile - outside	780x55x20		2
59	Door frame cover profile - inside	1950x55x20		1
60	Door frame cover profile - inside	800x55x20		1
Interior				
61	Bench	1900x500x88		2
62	Stool	700x500x88		1
63	Stool legs	328x28x88		4
64	Backrest	1900x220x48		1
65	Bench support	495x88x28		2
66	Bench support	900x88x28		2
67	heater safety guard	1000x88x28		2
68	heater safety guard	490x70x28		1
69	heater safety guard	675 x70x28		1
70	heater safety guard	575x88x28		1



No.	Name	Dimensions (cm)	Item code	pcs
71	LED support slat		800x25x25	1
Accessories				
72	LED 76 cm withe		LED-W-76-BS	1
73	Power supply 12V30W		PS-12V30W	1
74	Air vent grill	250x250x30		2
75	Sauna ventilation cover	215x170x20mm	SAS24620P	2
76	Polymer Adhesive (290ml)			2
77	Air ventilation covers	Ø 65mm		8
78	Stainless steel Drain	2050x135x35		1
79	Bitumen roof felt	2650x1000		4
80	Bitumen roof shingles		SH-B-16-232	4
81	Bitumen sealant	300ml		2
82	Iron pins			160
83	Assembly material set			1
84	Assembly instructions			1





Soma

120x100x190 cm

Itm.Nr. SGV1210MT

No.	Name	Dimensions (cm)	Item code	pcs
1	Touch screen control panel (Onni, Soma)		SP-IRC001	
2	Temperature sensor (Onni, Soma)		SP-IRC002	
3	Door hinge (Onni, Soma)		SP-IRC003	
4	Door seal (Onni, Soma)		SP-IRC005	
5	Reading light white (Onni, Soma)		SP-IRC006	
6	Speakers (Onni, Soma)		SP-IRC008	
7	Inner installation buckle (Onni, Soma)		SP-IRC009	
8	Door handle Hemlock/Hemlock (Soma)		SP-IRC015	
9	Power unit, 230V (Onni, Soma)		SP-IRC010	
10	Dimmer, 230V (Onni, Soma)		SP-IRC011	
11	Heating plate, 380W, 230V (Onni, Soma)	750x500	SP-IRC012	
12	Heating plate, 150W, 230V (Onni, Soma)	600x300	SP-IRC013	
13	Heating plate, 200W, 230V (Onni, Soma)	1000x300	SP-IRC014	
14	Sparepart heating element VitaMy 350		SP-VIS350	
15	Sparepart glass for VitaMy 350, VitaMy Duo		SP-VIGS	



HOW TO REPLACE THE HEATING ELEMENTS

Cilindro Corner / Cilindro Corner XE

Itm.Nr. HPCCE704, HPCCE904, HPCC704XE, HPCC904XE

Cilindro Pro

Itm.Nr. HPCE100400, HPCE165400, HPCE100400M, HPCE165400M

Modulo Alto

Itm.Nr. HMDA1654G, HMDA1654GL, HMDA1654GR, HMDA1654C

Modulo

Itm.Nr. HMD135400, HMD1354H, HMD1354GL, HMD1354GR, HMD1354G, HMD160400, HMD1604H, HMD1604GR, HMD1604GL, HMD1604G, HMD180400, HMD1804H, HMD1804GR, HMD1804GL, HMD1804G

Qube Combi

Itm.Nr. HQU1004CM, HQU1354CM, HQU1604CM



Cilindro Corner / Cilindro Corner XE

Itm.Nr. HPCCE704, HPCCE904, HPCC704XE, HPCC904XE

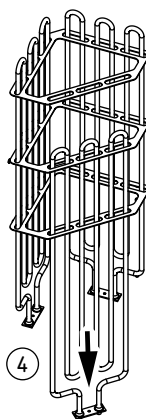
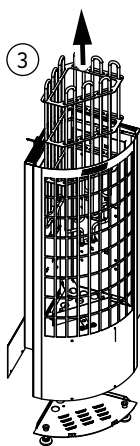
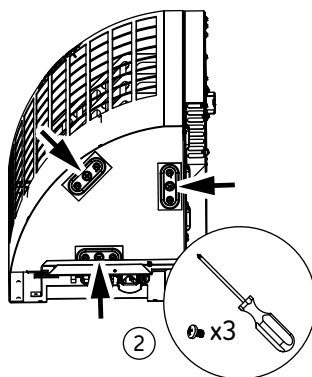
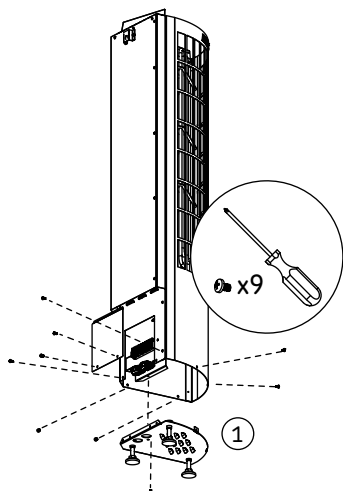

Cilindro Pro

Itm.Nr. HPCE100400, HPCE165400, HPCE100400M, HPCE165400M

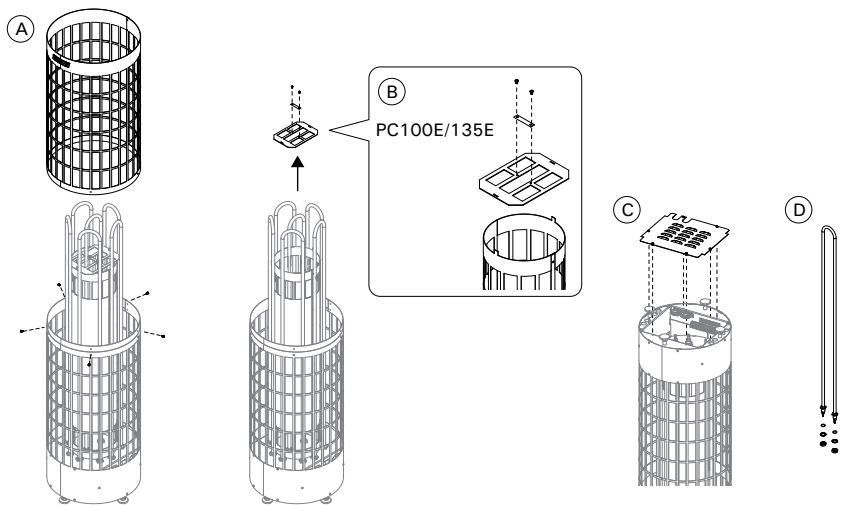

Modulo Alto

Itm.Nr. HMDA1654G, HMDA1654GL, HMDA1654GR, HMDA1654C

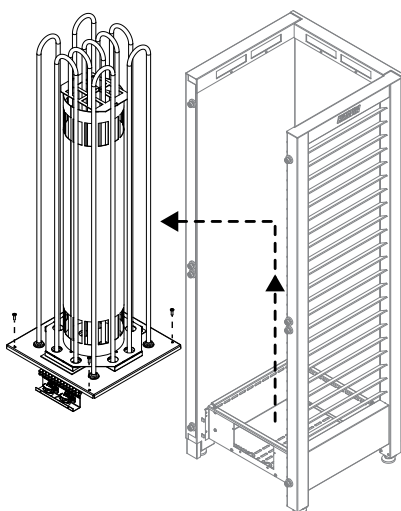
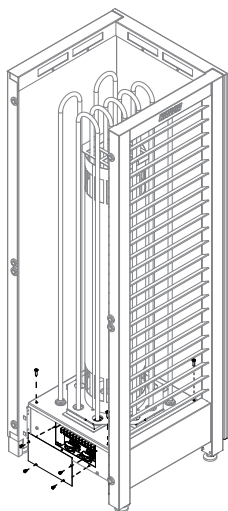
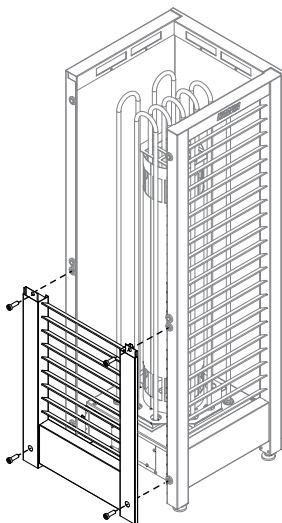
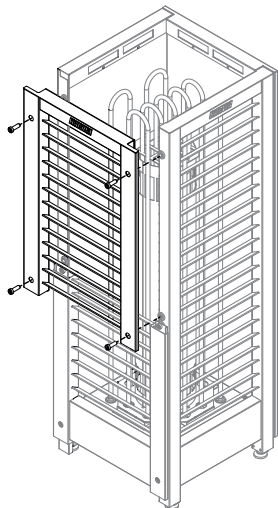

Modulo

Itm.Nr. HMD135400, HMD1354H, HMD1354GL, HMD1354GR, HMD1354G, HMD160400, HMD1604H, HMD1604GR, HMD1604GL, HMD1604G, HMD180400, HMD1804H, HMD1804GR, HMD1804GL, HMD1804G

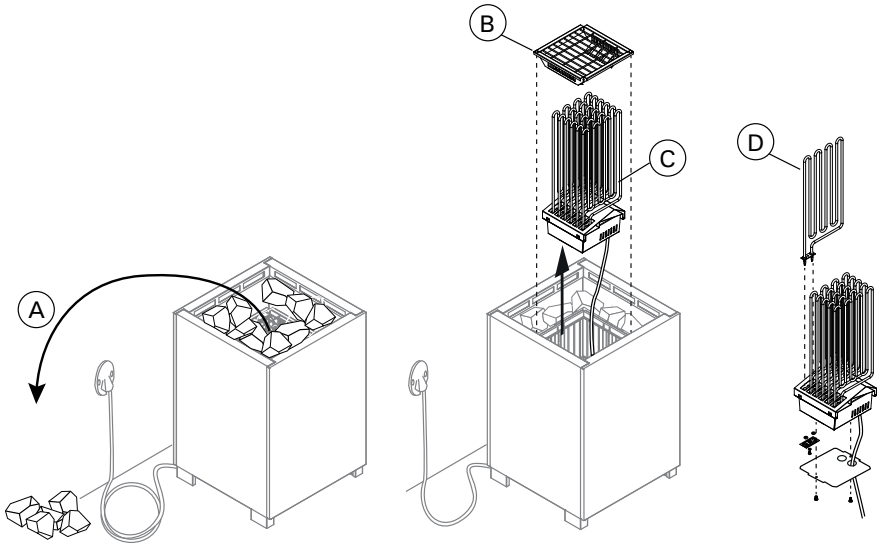

Qube Combi

Itm.Nr. HQU1004CM, HQU1354CM, HQU1604CM

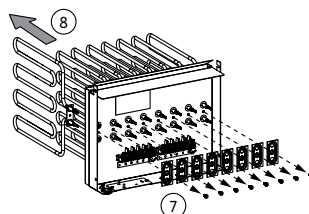
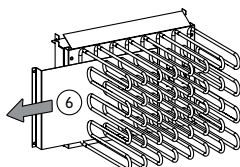
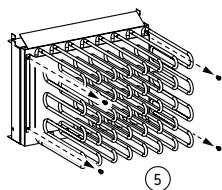
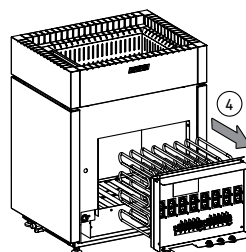
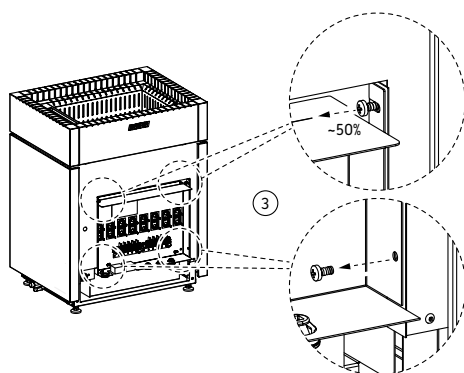
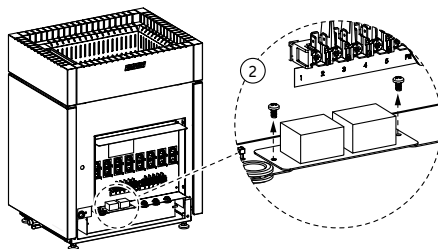
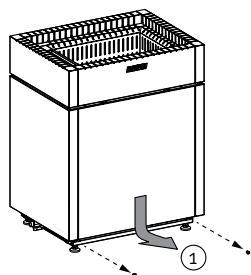

HARVIA HEATING ELEMENTS COMPATIBILITY

Product	Heating element(s)	pcs	Heating element(s)	pcs
Cilindro				
Cilindro PC66(E)	SPZSC-022	3		
Cilindro PC70(E/H/F/EE/HEE/XE/XW)	SPZRH-720	3		
Cilindro PC90(E/H/F/EE/HEE/XE/XW)	SPZSE-259	3		
Cilindro PC110(E/EE/HEE//XE/XW)	SPZSC-360	3		
Cilindro Plus				
Cilindro Plus PP70(E/SP)	SPZRH-720	3		
Cilindro Plus PP90(E/SP)	SPZSE-259	3		
Cilindro Pro				
Cilindro Pro PC100E/135E	SPZSC-022	6		
Cilindro Pro PC165E/200E	SPZSC-022	9		
Club				
Club K9 (old)	ZSL-310	3	ZSL-313	3
Club K10,5 (old)	ZSL-313	6		
Club K12 (old)	ZSL-313	3	ZSL-316	3
Club K15 (old)	ZSL-316	6		
Club K11G	SPZSP-240	3	SPZSS-110	3
Club K13,5G	SPZSP-250	3	SPZSS-120	3
Club K15G	SPZSP-250	6		
Club Japan				
Club K12G	SPZSP-250I	6		
Club K15G	SPZSP-255I	6		
Club Combi				
Club Combi K11GS-K15GS	SPZH-104: 1	1		
Club Pro / Profi				
Profi L20	ZSK-732	6		
Profi L23	ZSL-310	6	ZSL-314	6
Profi L26	ZSL-313	6	ZSL-314	6
Profi L30	ZSL-314	12		
Profi L33	ZSL-318	12		
Club Pro Japan				
Club Pro L33	ZSK-745I	12		
Compact JM				
Compact JM20(E)	SPZSJ-100	2		
Compact JM25(E)	SPZSJ-100	1	SPZSJ-110	1
Compact JM30(E)	SPZSJ-110	2		
Delta				
Delta D23(E, EE, XE, XW)	SPZSN-150	2		
Delta D29(EE)	SPZSN-150	1	SPZSN-160	1
Delta D36(E, EE, XE, XW)	SPZSN-160	2		
Delta Japan				
Delta D36	SPZSN-160	2		
Delta Combi				
D29SE	SPZSN-210	1	SPZH-104	1



Product	Heating element(s)	pcs	Heating element(s)	pcs
Figaro				
Figaro FG70(E)/Quatro QR70	SPZRH-720	3		
Figaro FG90(E)/Quatro QR90	SPZSE-259	3		
Fuga				
Fuga FU90(E)	SPZSE-259	3		
Forte				
Forte AF4 / AFB4	SPZSF-20U	3		
Forte AF6 / AFB6	SPZSF-30	3		
Forte AF9 / AFB9	SPZSF-50	3		
Globe				
Globe GL70/E	SPZVO-201	3		
Globe GL110/E	SPZVO-200	3		
Glow / Glow Corner				
Glow TRT70 / TRC70 / TRT70E / TRC70E	SPZRH-720	3		
Glow TRT90 / TRC90 / TRT90E / TRC90E	SPZSE-259	3		
KIP / Sähköri				
KIP/KV30(E)	SPZSK-690	2		
KIP/KV/M45/V45E	SPZSK-690	3		
KIP/KV/M60/V60E/CS60	SPZSK-700	3		
KIP/KV/M80/V80E/CS80	SPZSK-710	3		
KIP/M90E	SPZSK-720	3		
KIP US/CA				
KIP30(B/W) 240VAC	ZSK-725	3		
KIP45(B/W) 240VAC	ZSL-310	3		
KIP60(B/W) 240VAC	ZSL-313	3		
KIP80(B/W) 240VAC	ZSL-316I	3		
KIP30(B/W) 208VAC				
KIP45(B/W) 208VAC	ZSK-738	3		
KIP60(B/W) 208VAC	ZSK-742	3		
KIP80(B/W) 208VAC	ZSK-745I	3		
KIP JP				
KIP60E	ZSK-742I	3		
KIP80E	ZSK-745I	3		
Kivi				
Kivi PI70(E)	SPZRH-247	3		
Kivi PI90(E)	SPZRH-249	3		
Legend				
Legend PO70/E/XE/XW	SPZRH-720	3		
Legend PO110/E/XE/XW	SPZSC-360	3		
Legend Pro				
Legend PO11	SPZSP-240	3	SPZSS-110	3
Legend PO165	SPZSP-250	3	SPZSP-255	3
Modulo				
Modulo 135	SPZCU-823	6		
Modulo 160	SPZCU-823	3	SPZCU-830	3
Modulo 180	SPZCU-830	6		



Product	Heating element(s)	pcs	Heating element(s)	pcs
Modulo Alto				
Modulo Alto MDA165/200	SPZSC-022	9		
Spirit				
Spirit HSP60(E)	SPY10-0015	3		
Spirit HSP90(E)	SPZCU-830	3		
The Wall				
The Wall SW45/E	SPY10-0016	3		
The Wall SW60/E	SPY10-0015	3		
The Wall SW80/E	SPY10-0014	3		
The Wall SW90/E	SPZCU-830	3		
The Wall Combi				
The Wall Combi SW45S/SA	SPZCU-823	2	SPZH-104	1
The Wall Combi SW70S/SA	SPZCU-823	3	SPZH-104	1
The Wall Combi SW90S/SA	SPZCU-830	3	SPZH-104	1
Topclass Combi				
Topclass Combi KV50SE(A)	SPZSK-690	3	SPZH-104	1
Topclass Combi KV60SE(A)	SPZSK-700	3	SPZH-104	1
Topclass Combi KV80SE(A)	SPZSK-710	3	SPZH-104	1
Topclass Combi KV90SE(A)	SPZSK-720	3	SPZH-104	1
Unio				
Unio HNK360(E,EE)	SPZSC-360	1		
Vega Compact				
Vega Compact BC23(E)	SPZSB-770	2		
Vega Compact BC35(E)	SPZSB-770	3		
Vega				
Vega BC45(E)	SPZSB-224	3		
Vega BC60(E)	SPZSB-226	3		
Vega BC80(E)	SPZSB-228	3		
Vega BC90(E)	SPZSB-229	3		
Vega Compact				
Vega Combi BC60SE(A)	SPZSB-226	3	SPZSB-571	1
Vega Combi BC90SE(A)	SPZSB-229	3	SPZSB-571	1
Vega Pro				
Vega Pro BC105	SPZSB-461	6		
Vega Pro BC135	SPZSB-461	3	SPZSB-462	3
Vega Pro BC165	SPZSB-462	6		
Virta				
Virta HL70	SPZCU-823	3		
Virta HL90	SPZCU-830	3		
Virta HL110	SPZCU-836	3		
Virta Combi				
Virta Combi HL70S (A)	SPZCU-823	3	SPZH-104	1
Virta Combi HL90S (A)	SPZCU-830	3	SPZH-104	1
Virta Combi HL110S (A)	SPZCU-836	3	SPZH-104	1



Product	Heating element(s)	pcs	Heating element(s)	pcs
Virta Pro				
Virta Pro HL135/steel	SPZCU-823	6		
Virta Pro HL160/steel	SPZCU-823	3	SPZCU-830	3
Virta Pro HL220/steel	SPZCU-836	6		
Virta Pro Combi				
Virta Pro Combi HL135SA/steel	SPZCU-823	6	SPZH-104	2
Virta Pro Combi, HL160SA/steel	SPZCU-823	3	SPZCU-830	3
	SPZH-104	2		
Virta Pro Combi HL220SA/steel	SPZCU-836	6	SPZH-104	2
Qube				
Qube 9 kW	SPSEN-002	6		
Qube 12 kW	SPSEN-002	3	SPSEN-003	3
Qube 15 kW	SPSEN-002	6	SPSEN-003	
Qube Pro 24 kW	SPSEN-003	12		
Qube Pro 36 kW	SPSEN-012	18		
Home				
HOME-F45	SPSEN-006	3		
HOME-F60	SPSEN-007	3		
HOME-F75	SPSEN-008	3		
HOME-F90	SPSEN-009	3		
Home Combi				
HOME-C60	SPSEN-007	3	SPZH-104	1
HOME-C90	SPSEN-009	3	SPZH-104	1

